

INSTRUCTIONS

BM1510

REV# 1



INSTRUCTIONS

BM1500

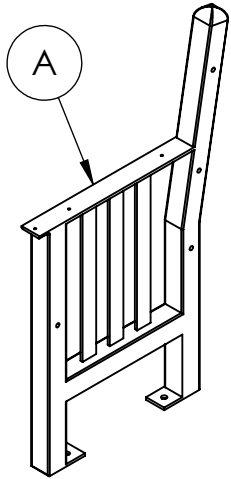

2
Bench Ends

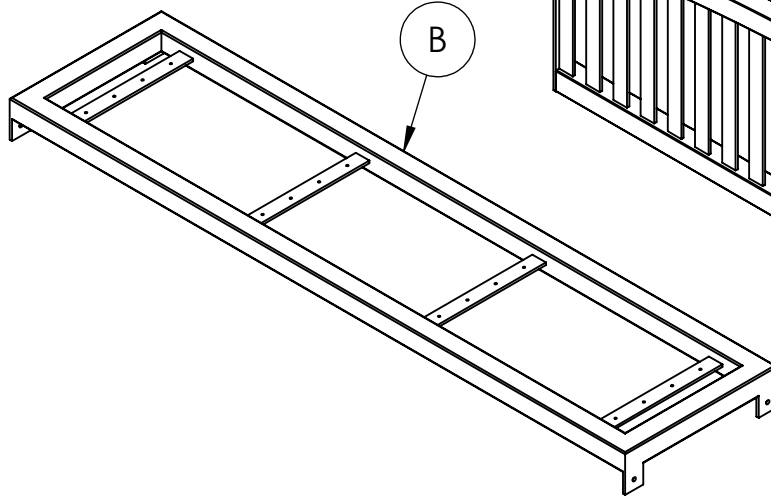

1
Seat Frame

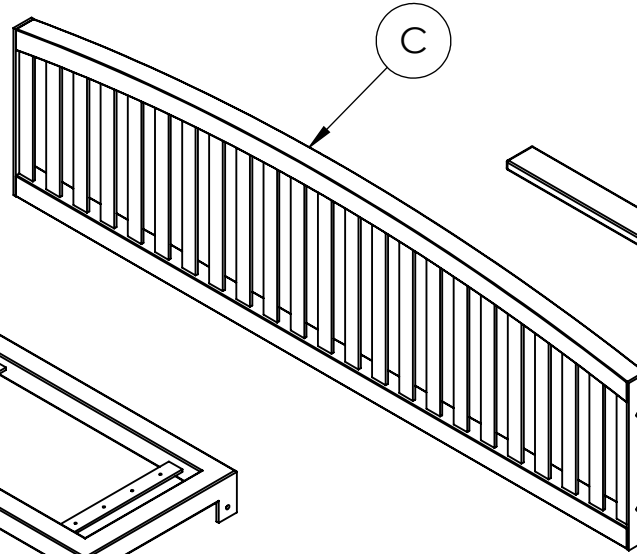

1
Back Assembly

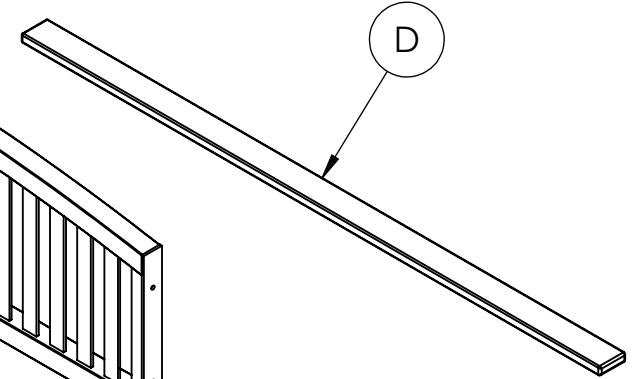

4
Seat Slats

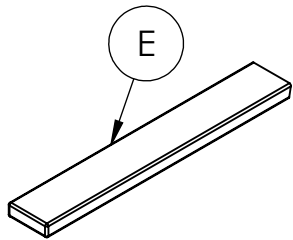

2
Arm Rests

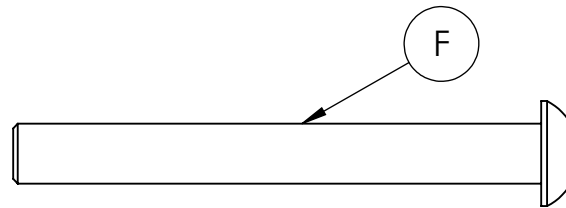

8
5/16" x 2.75" Button Head
Cap Screw

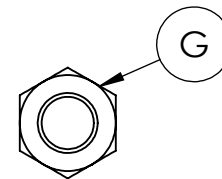

8
5/16" Hex Nuts

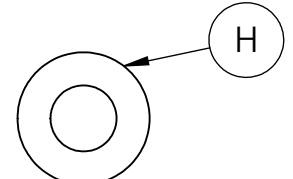

16
5/16" Flat Washer

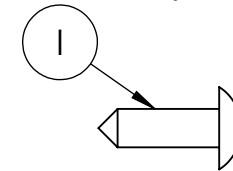

18
#10 x .75" Pan Head Screws

REQUIRED TOOLS (NOT INCLUDED)

- 1 - #2 PHILLIPS BIT
- 1 - SCREWGUN OR POWER DRILL
- 1 - 1/2" WRENCH
- 1 - 1/4" ALLEN WRENCH

NOTE: IT IS IMPORTANT TO KEEP ALL SCREWS LOOSE DURING ASSEMBLY UNTIL ENTIRE BENCH IS ASSEMBLED

**HARDWARE &
TOOLS REQUIRED
FOR ASSEMBLY**

2/4

INSTRUCTIONS

BM1500

STEP 1 Seat Assembly

- Locate the bench ends (A) and the seat frame (B)
- Insert (2) button head screws (F) with washers (H) thru the bench ends (A) and into the tab on the seat frame (B)
- Secure the bench end to the seat frame with washers (H) and hex nuts (G)
- Repeat for the other bench end

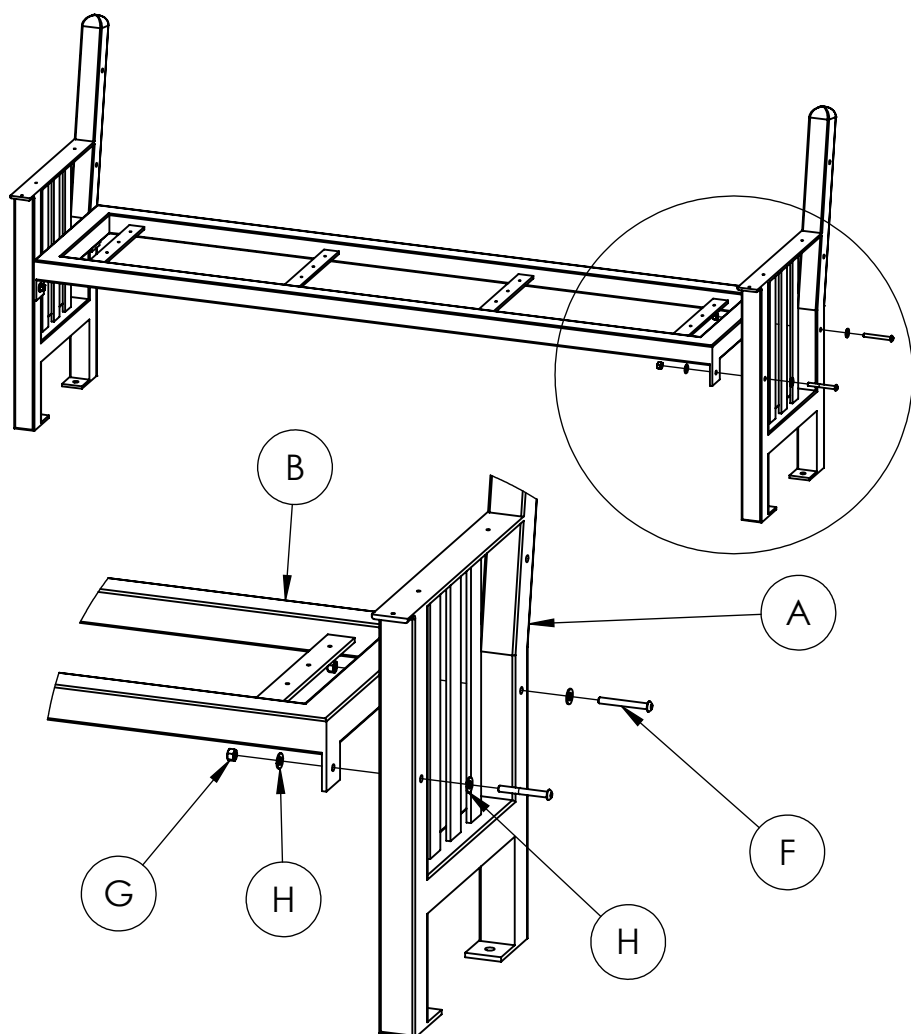

STEP 2 Backrest Assembly

- Hold the backrest assembly (C) in between the bench ends (A)
- The slats are flush to the front side of the assembly
- Align the holes in the bench ends (A) with the holes in backrest assembly (C)
- Insert (2) button head screws (F) with washers (H) through the holes and secure with washers (H) and hex nuts (G)
- Repeat for the other side

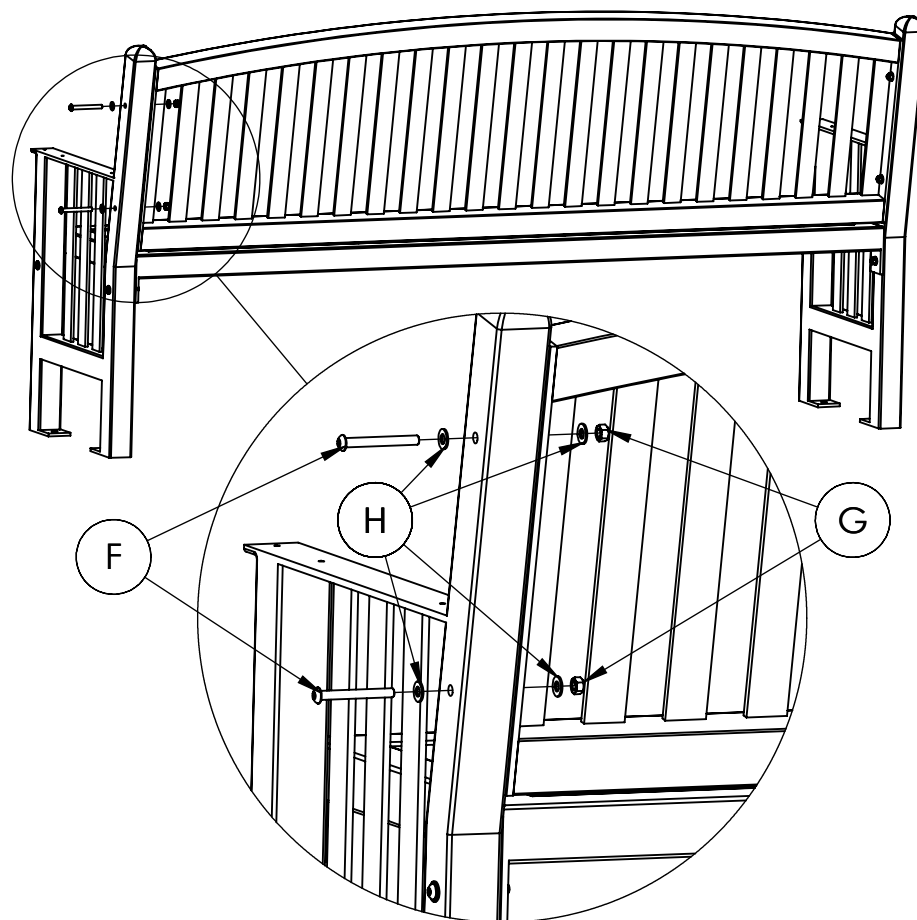

INSTRUCTIONS

BM1500

Step 3 Attach the Seat and Armrests

- Lay the seat slats (D) across the seat frame (B)
- Each seat slat has pre-marked location holes
- From the bottom align the holes in the seat frame (B) with the location holes in the seat slats (D) See Detail 1
- Secure the seat slats to the seat frame with #10 x .75" pan head screws (I)
- Align the holes in the bench ends (A) with the location holes in the armrests (E)
- Secure the armrests to the bench ends with #10 x .75" pan head screws (I) See Detail 2

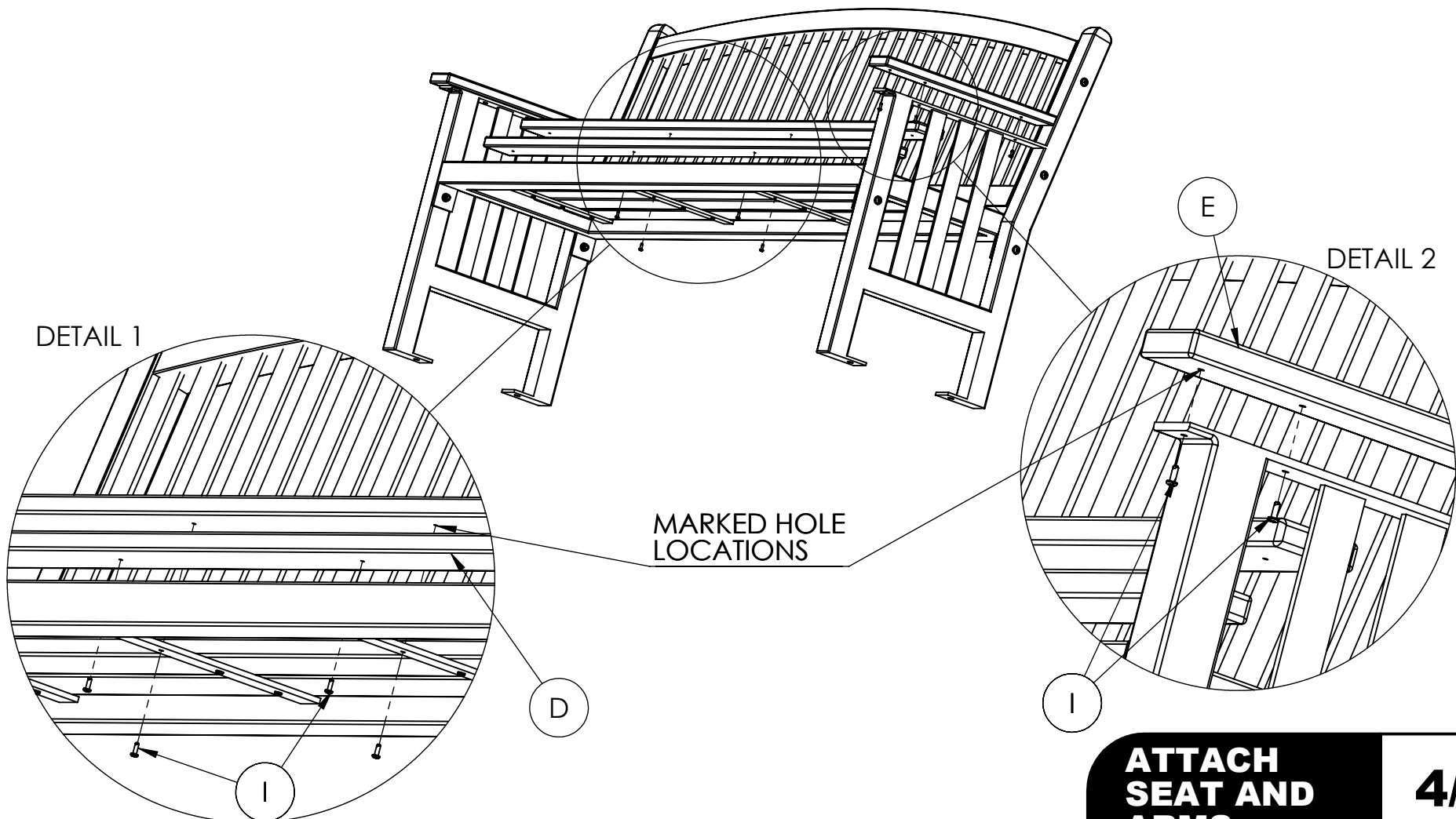

**ATTACH
SEAT AND
ARMS**

4/4

SPECS. BM1510

REV# 1

