

# MASON DINING TABLE

KCF7450  
REV.1  
1/22/26

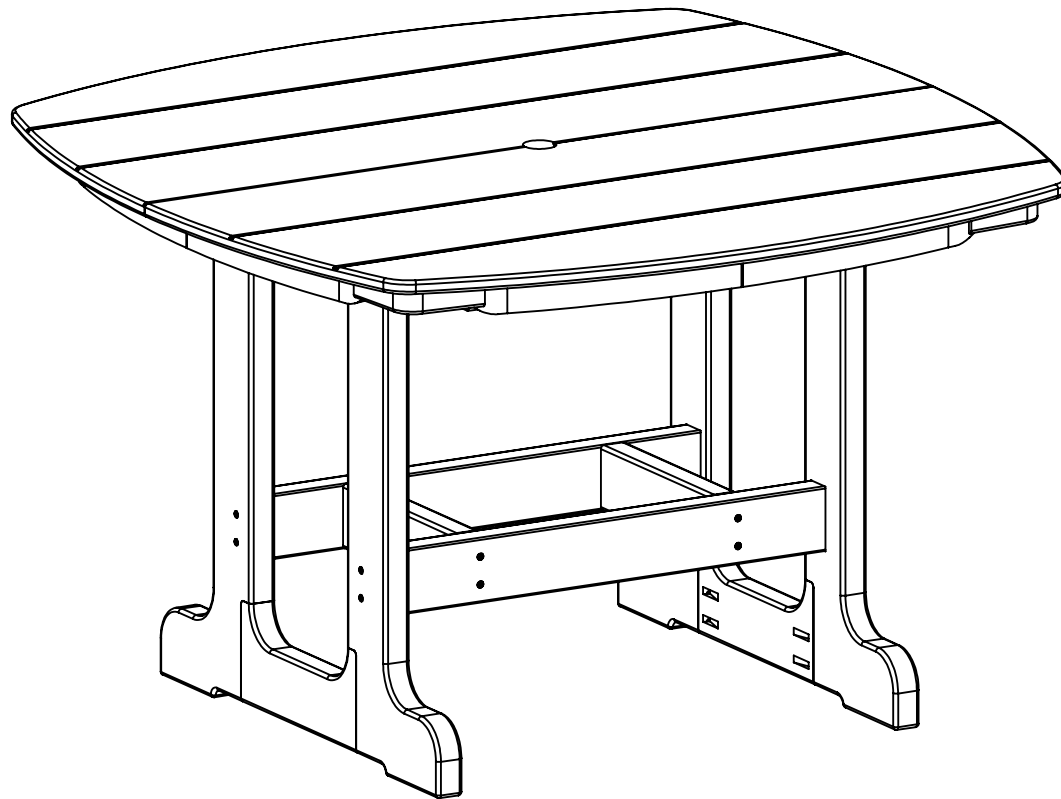

# MASON DINING TABLE

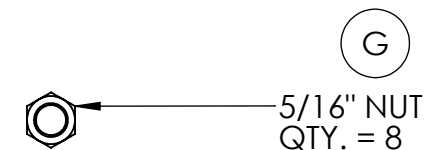
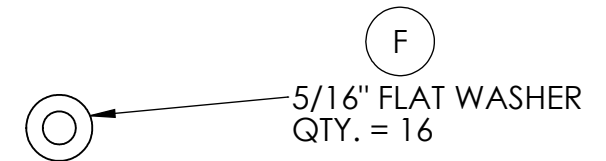
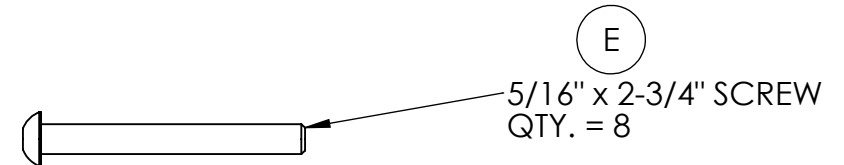
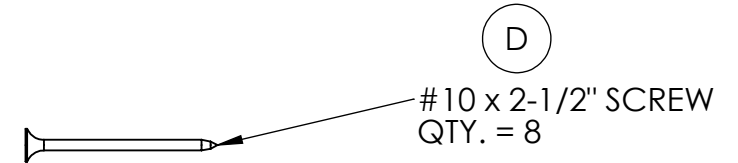
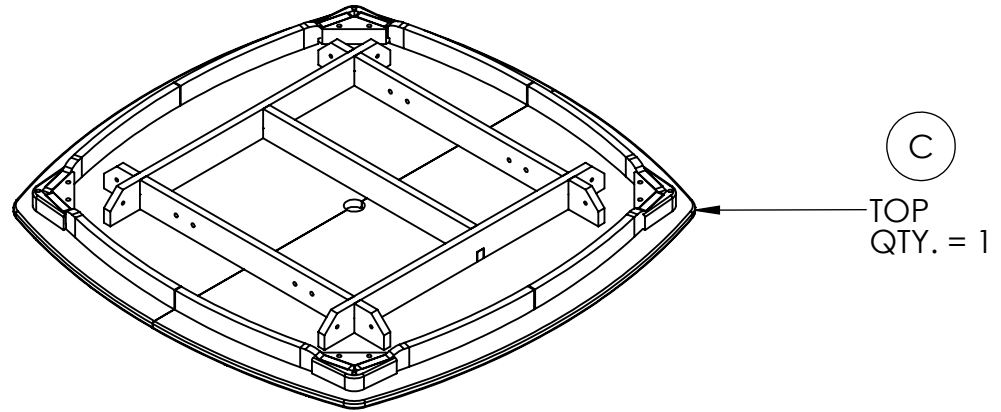
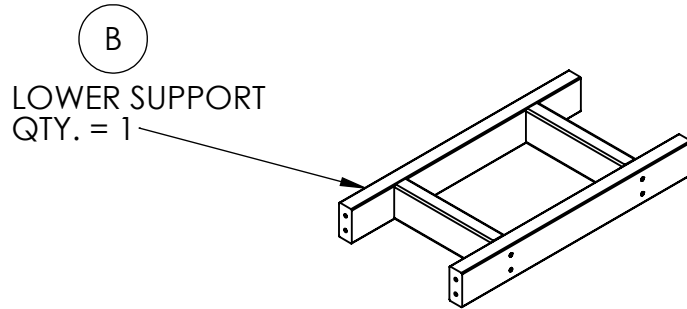
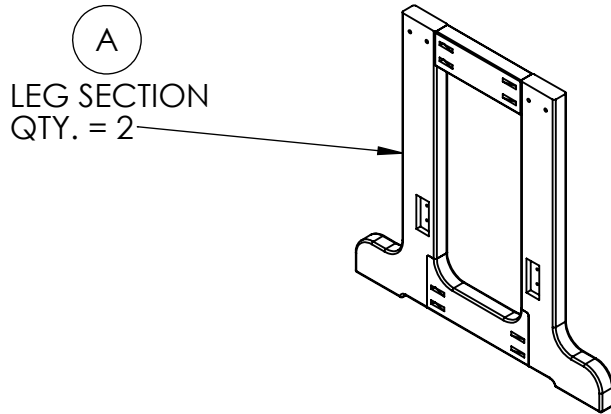

## REQUIRED TOOLS (NOT INCLUDED)

- POWER DRILL
- 3/16" ALLEN WRENCH
- 1/2" WRENCH OR SOCKET
- #2 SQUARE BIT

PARTS & HRDWR.  
FOR ASSEMBLY

1/3

# MASON DINING TABLE

STEP 1: BEGIN BY INSERTING THE ENDS OF THE LOWER SUPPORT (B), INTO THE CUTOUTS ON THE INSIDE FACE OF ONE OF THE LEG SECTIONS, ITEM (A). FASTEN WITH (4) 2" DECK SCREWS (D). INSERT SCREWS JUST UNTIL FLUSH. DO NOT OVER DRIVE THEM. REPEAT FOR THE OTHER LEG SECTION.

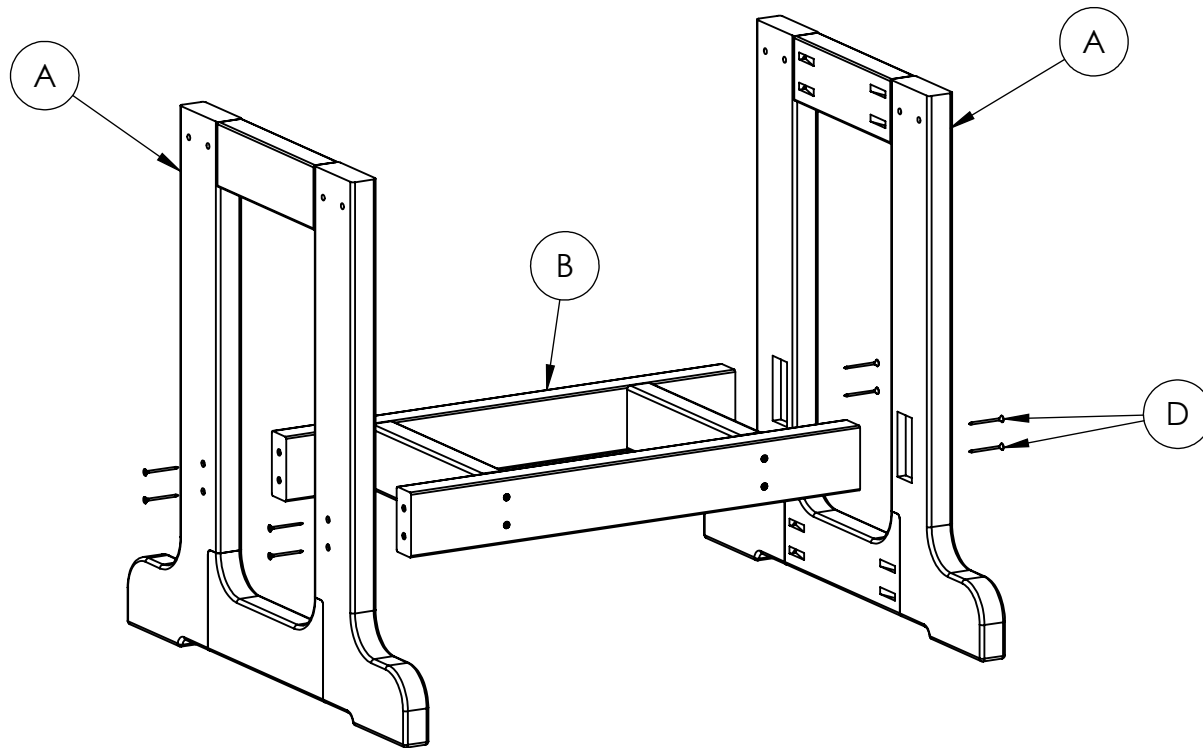

# MASON DINING TABLE

STEP 2: PLACE PREASSEMBLED TOP, ONTO THE LEGS AS SHOWN. THE LEGS AND TOP MUST BE ORIENTED AS SHOWN. THE LEGS WILL FIT INSIDE THE INNER STRUCTURE OF THE TOP. IF IT DOESN'T FALL INTO PLACE, DOUBLE CHECK THE ORIENTATION.

FASTEN THE TOP WITH A 5/16" MACHINE SCREW, (2) FLAT WASHERS, AND A 5/16" NUT FOR EACH OF THE (8) HOLES. TIGHTEN WITH 3/16" ALLEN WRENCH AND 1/2" WRENCH OR SOCKET.

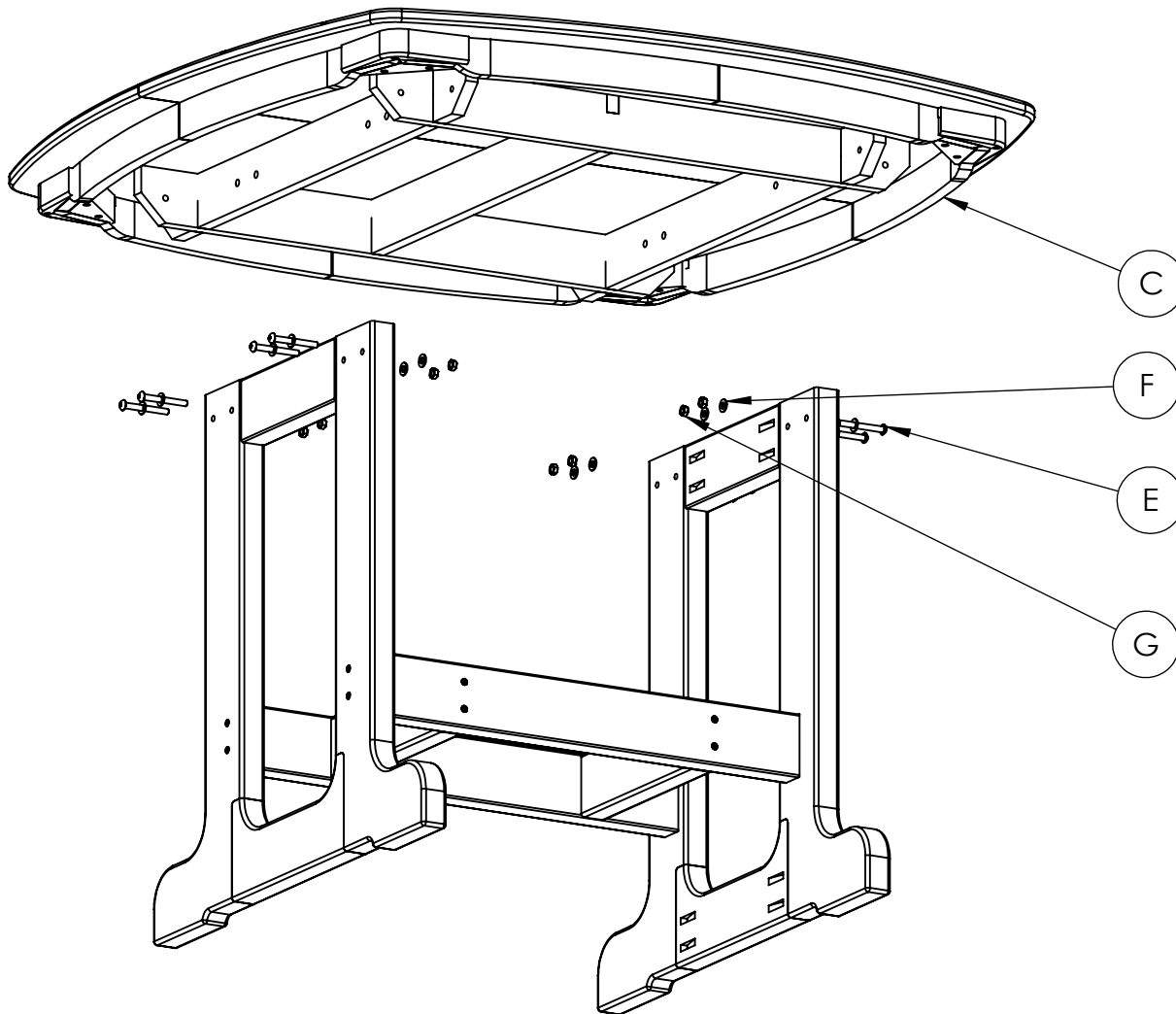

**INSTALL TOP**

**3/3**

# MASON DINING TABLE

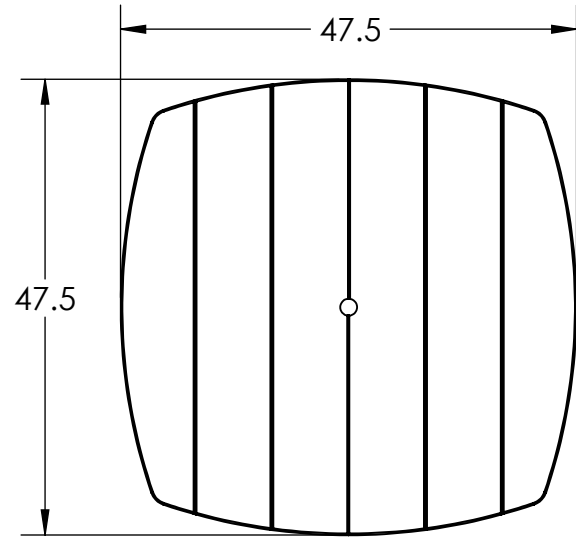

KCF7450  
REV. 1  
1/22/26

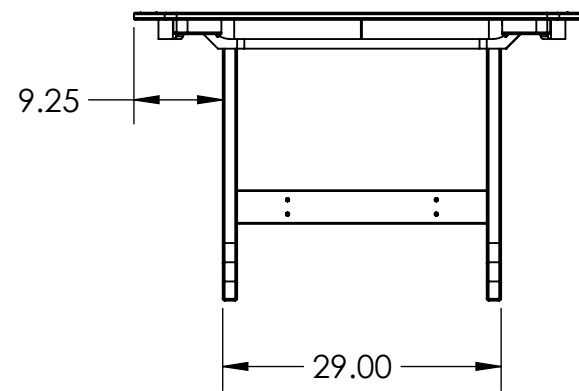
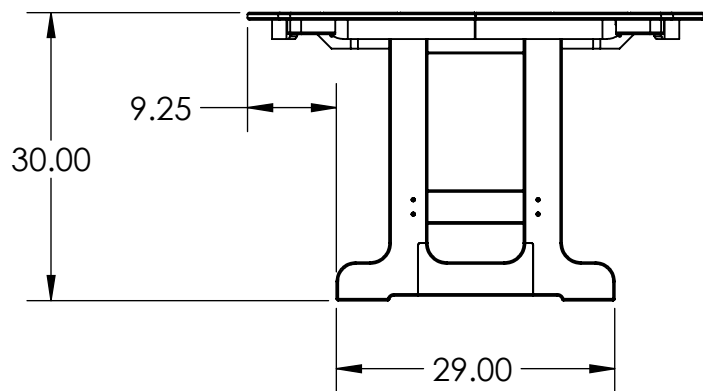

**CONSTRUCTION MATERIALS:**  
Recycled Plastic  
**HARDWARE:**  
Stainless Steel