

KCF7435
MASON SIDE TABLE

KCF7435 (SIDE TABLE)
REV. 1
12/17/25

KCF7435
SIDE TABLE

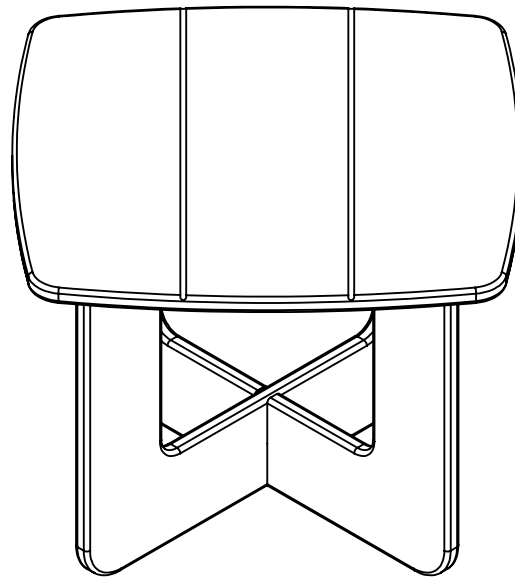

KCF7435 MASON SIDE TABLE

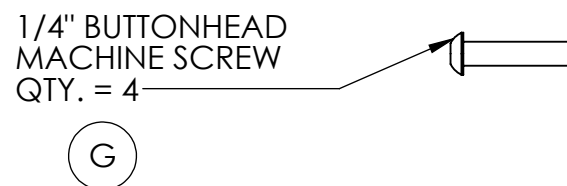
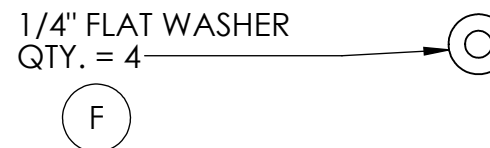
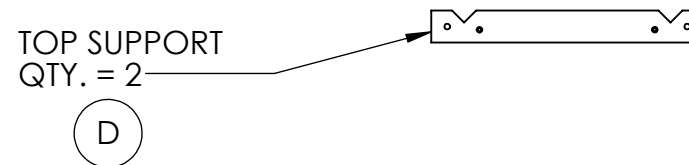
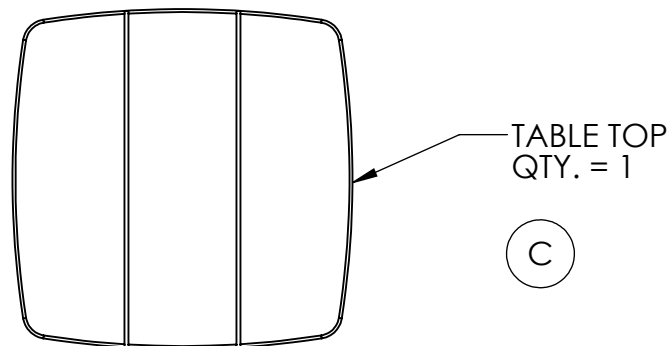
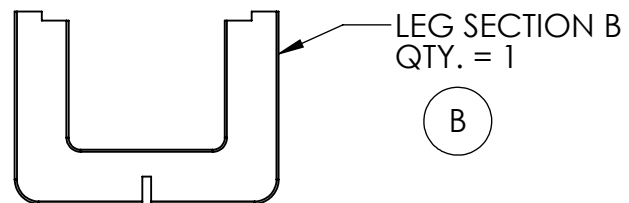
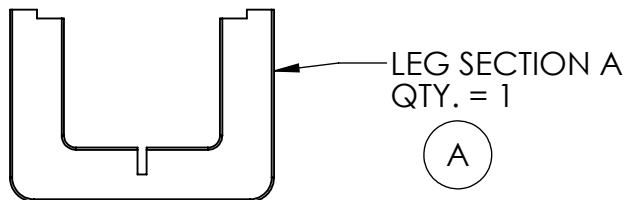

TOOLS NEEDED (NOT INCLUDED):

- 1/2" WRENCH OR SOCKET
- 6mm ALLEN WRENCH
- RUBBER Mallet

**PARTS & TOOLS
REQUIRED FOR
ASSEMBLY**

1/3

KCF7435 MASON SIDE TABLE

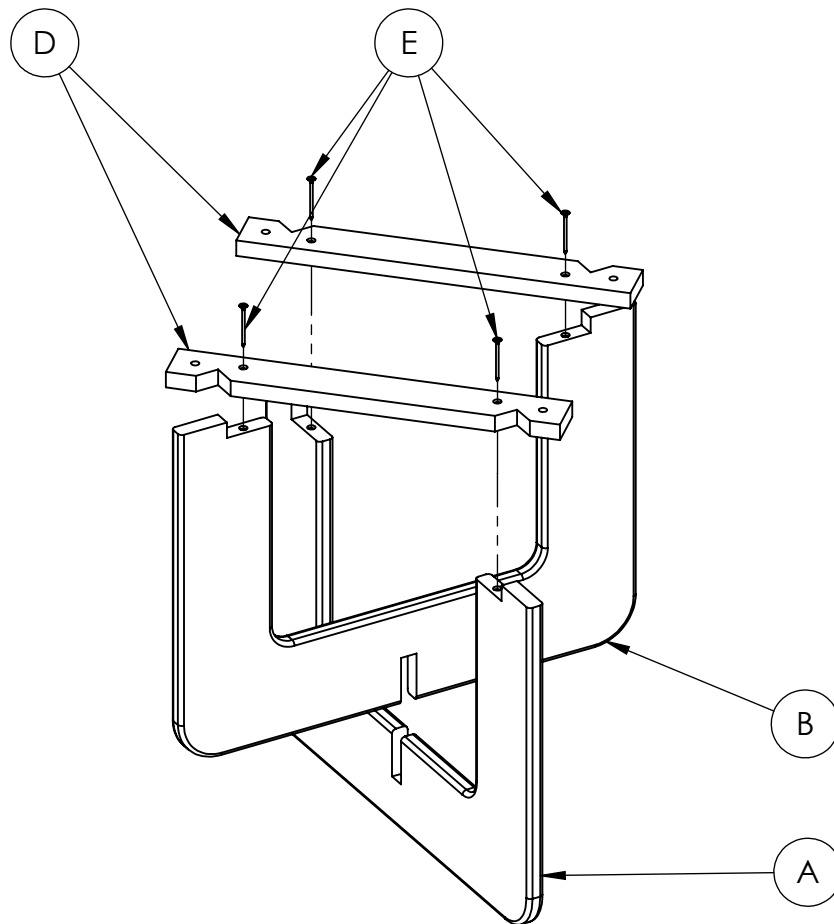

STEP 1: BEGIN BY STANDING UP BOTH OF THE LEG SECTIONS (A & B) SO THE NOTCHES LINE UP WITH EACH OTHER. PUSH THE SECTIONS INTO EACH OTHER UNTIL FULLY ENGAGED. USE A RUBBER Mallet IF NECESSARY.

NEXT, PLACE THE TOP SUPPORT PIECES (D) WITH THE COUNTERSINKS FACING UPWARD, ON TOP OF THE LEG SECTIONS AS SHOWN. SECURE USING (2) #10 x 2" SCREWS (E) EACH.

KCF7435 MASON SIDE TABLE

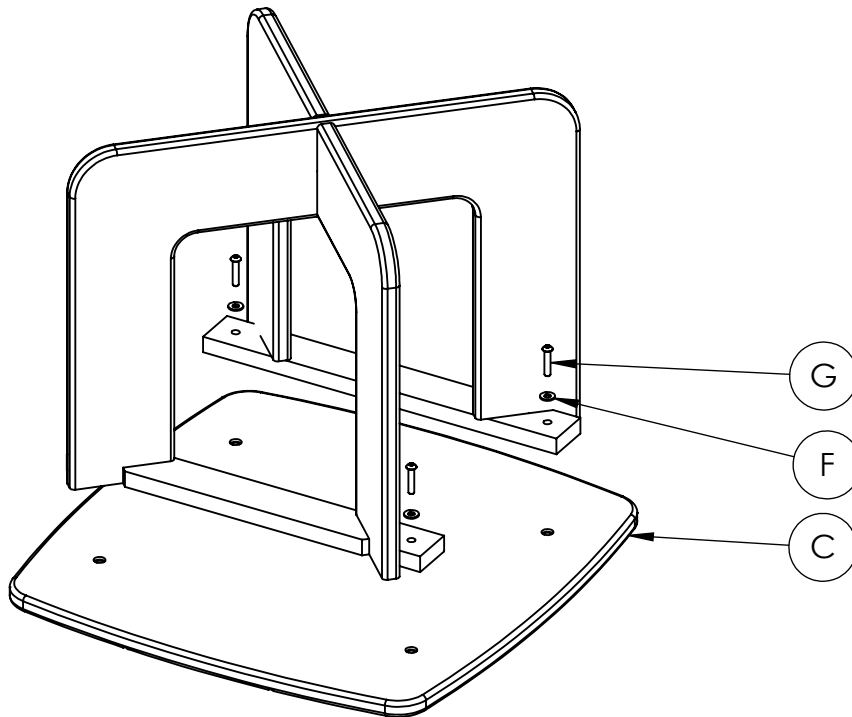

STEP 2: PLACE TABLE TOP, UPSIDE DOWN, ON A FLAT, SMOOTH SURFACE. PLACE THE ASSEMBLED LEG SECTIONS ONTO THE TABLE TOP, IN THE CORRECT ORIENTATION. TAKE NOTE OF THE HOLE LOCATIONS AS THEY ARE NOT SYMETRICAL.

FASTEN LEGS TO TOP USING (4) 1/4" BUTTON-HEAD MACHINE SCREWS (G) WITH (4) 1/4" FLAT WASHERS (F).

KCF7435 MASON SIDE TABLE

REV #1 12/18/25

KCF7435
SIDE TABLE

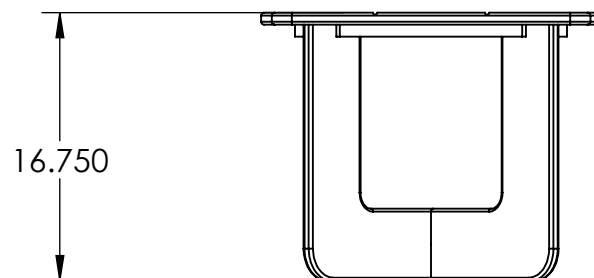
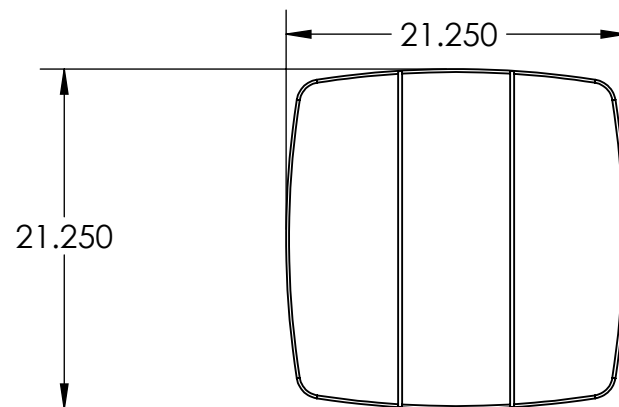

NOTE: ALL MATERIAL RECYCLED PLASTIC UNLESS NOTED

ALL DIMENSIONS ARE SHOWN IN INCHES