

INSTRUCTIONS

ADP3200 REV# 1

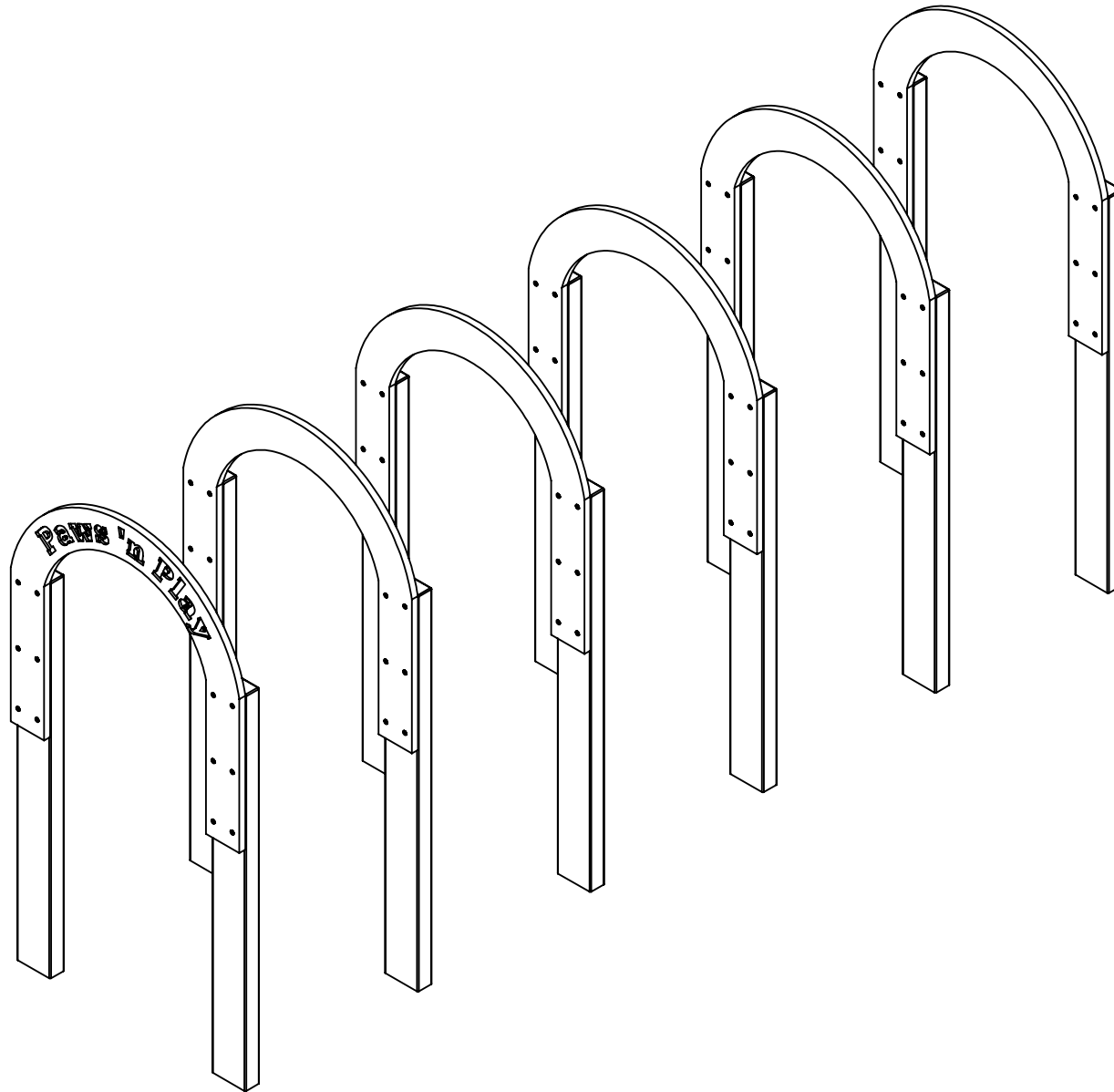

INSTRUCTIONS

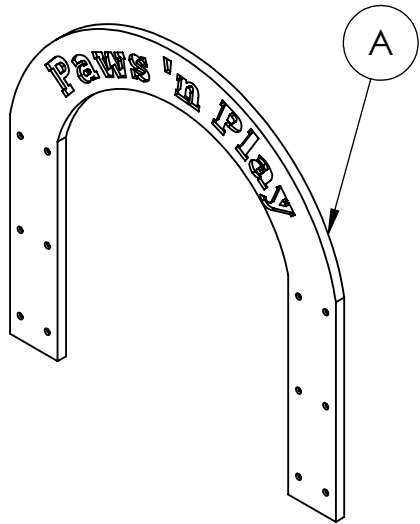

1
ENGRAVED ARCHWAY

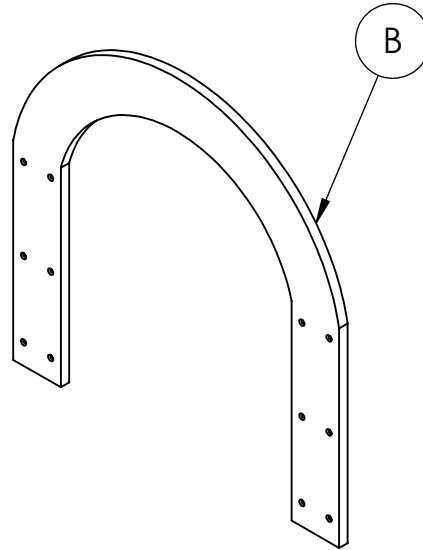

5
ARCHWAYS

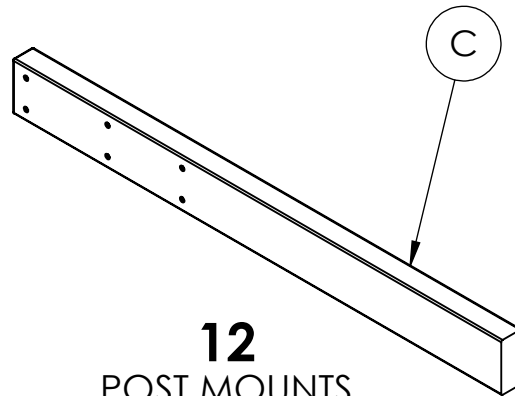

12
POST MOUNTS

REQUIRED TOOLS (NOT INCLUDED)

- POWER DRILL
- #2 SQUARE DRIVE

HARDWARE

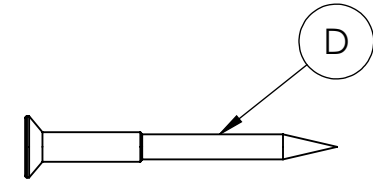

72
#8 x 1.625"
FLAT HEAD SCREW

**HARDWARE &
TOOLS REQUIRED
FOR ASSEMBLY**

2/5

INSTRUCTIONS

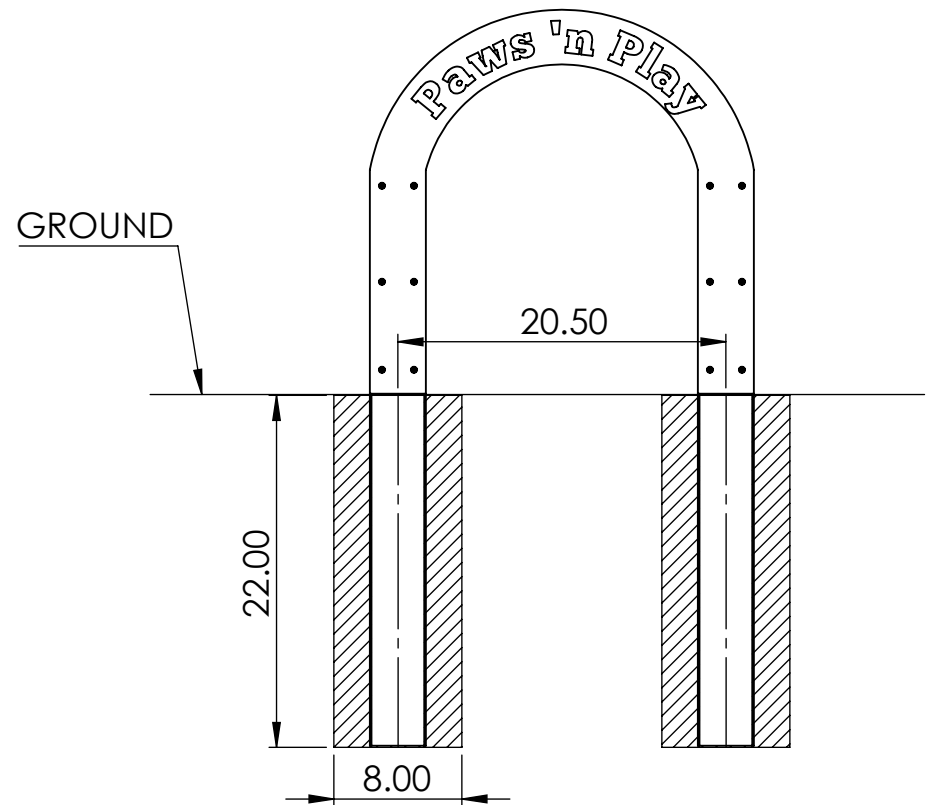
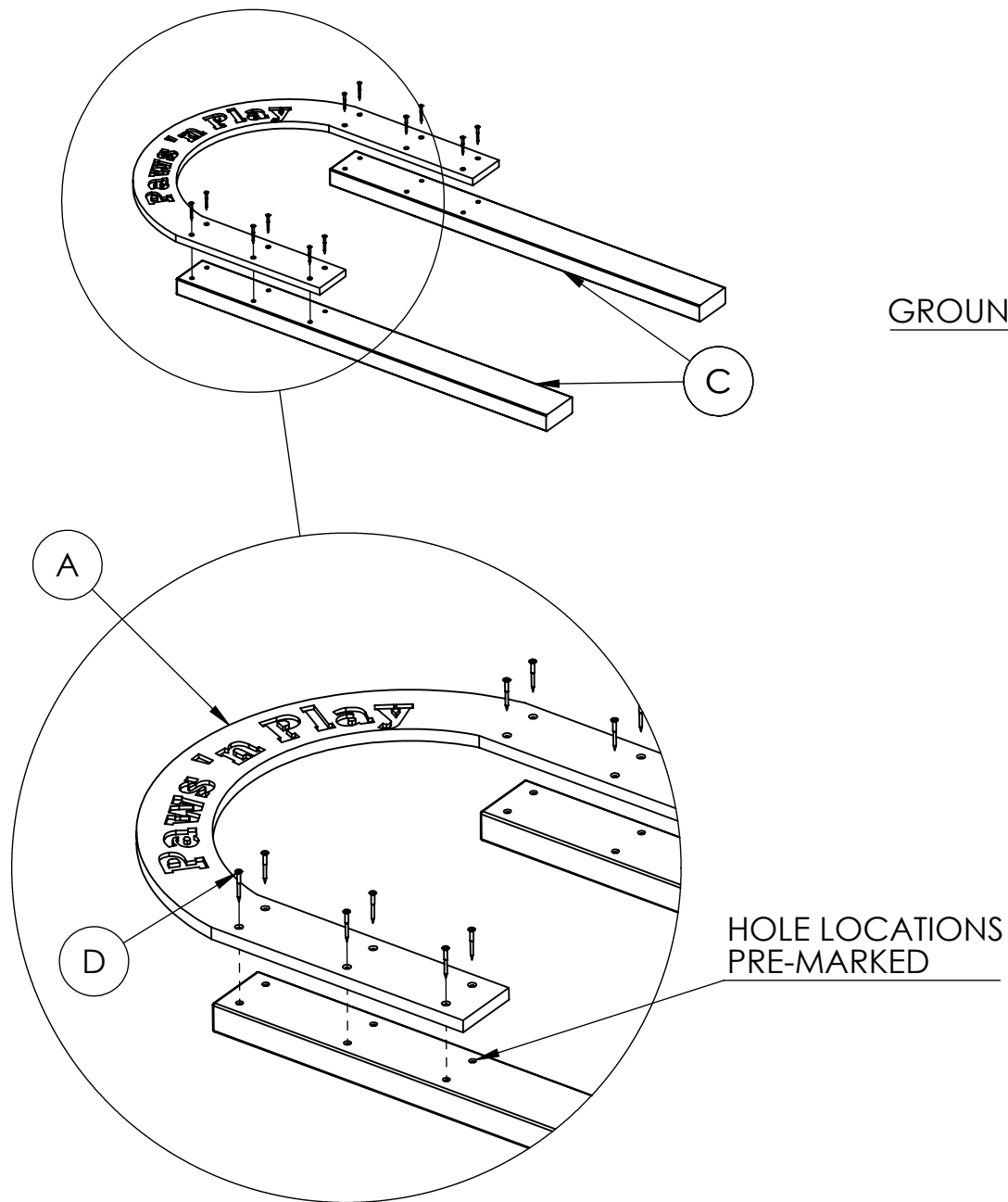

INSTRUCTIONS

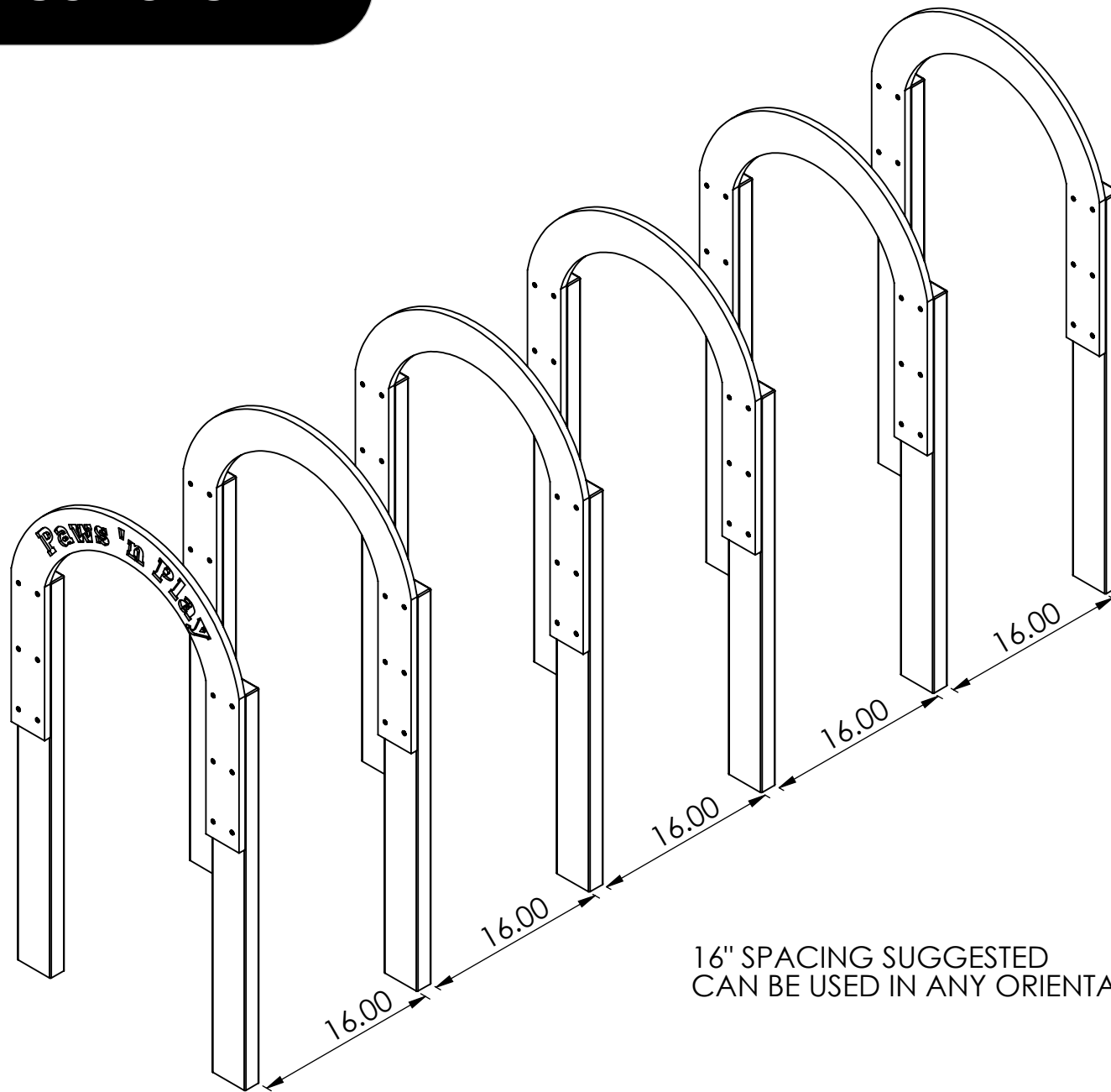

16" SPACING SUGGESTED
CAN BE USED IN ANY ORIENTATION OR SPACING

SPECIFICATIONS

ALL DIMENSIONS SHOWN IN INCHES

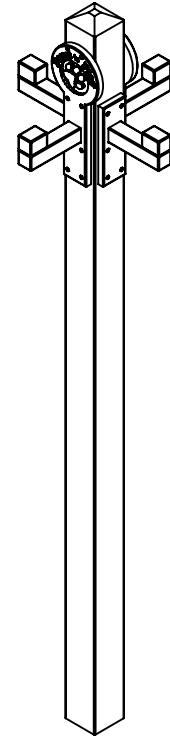
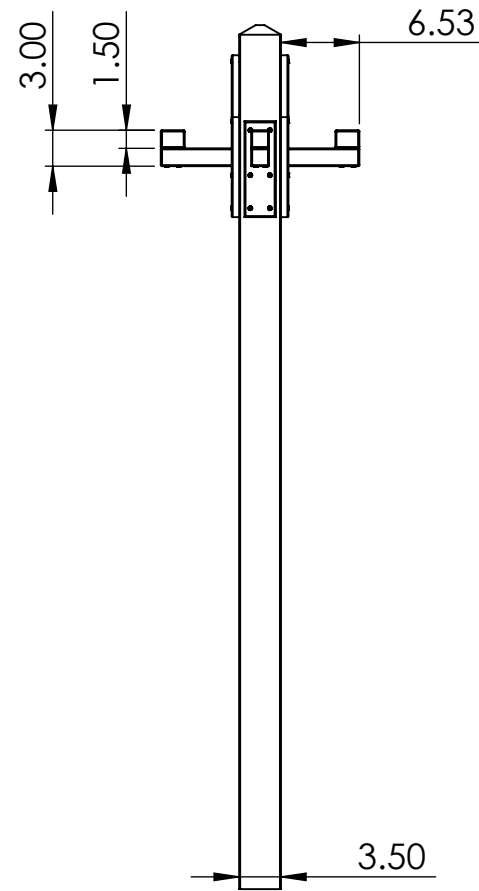
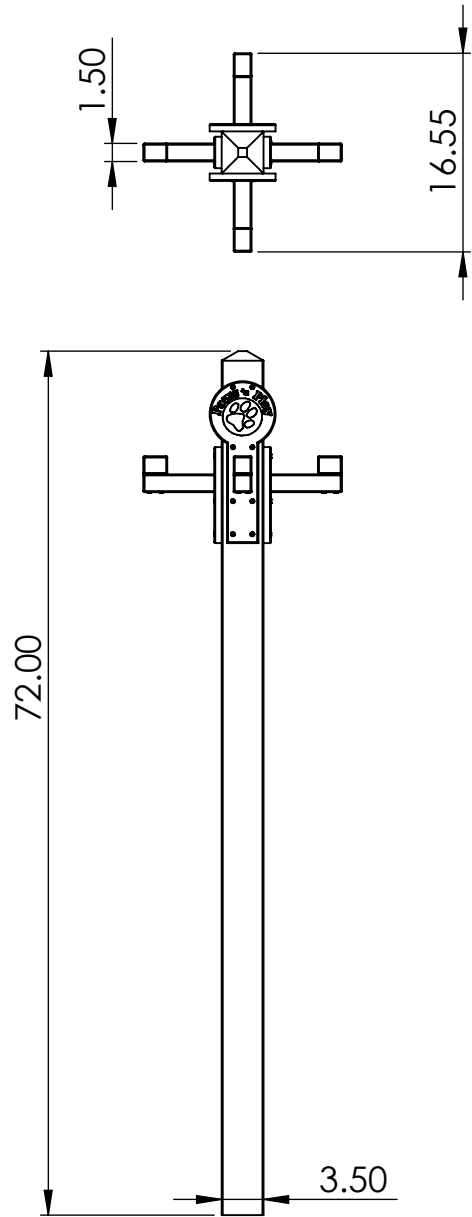

CONSTRUCTION MATERIALS:
Recycled Plastic
HARDWARE:
Stainless Steel