

**KCF7455
MASON LARGE DINING TABLE**

KCF7455
REV. 1
1/29/26

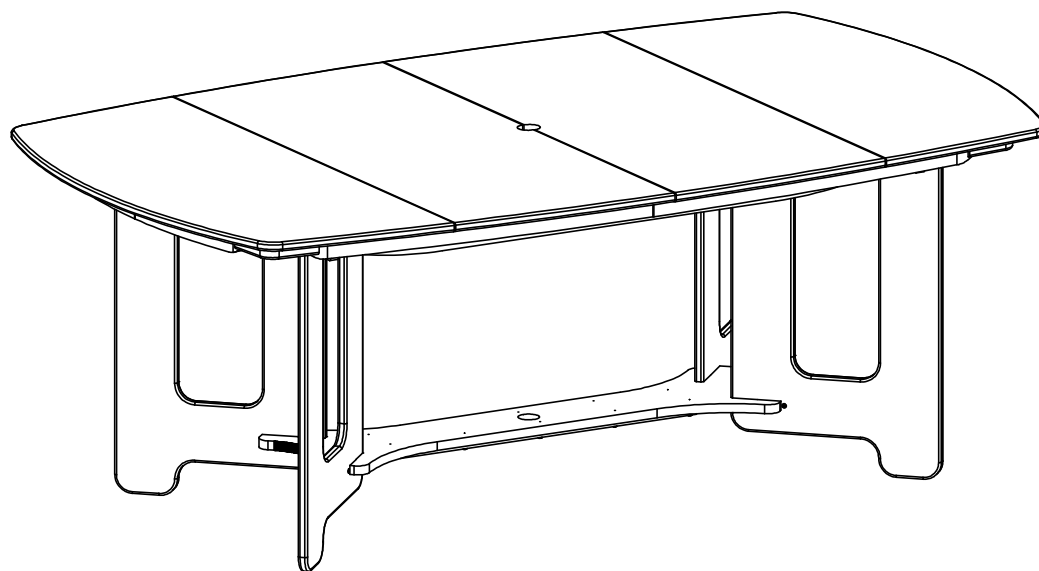

KCF7455 MASON LARGE DINING TABLE

LEFT LEG
QTY. = 2

(A)

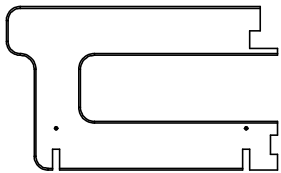

RIGHT LEG
QTY. = 2

(B)

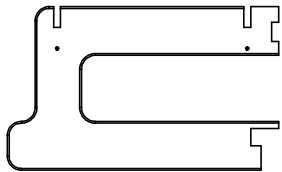

LOWER
DOG BONE
QTY. = 1

(C)

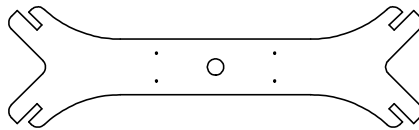
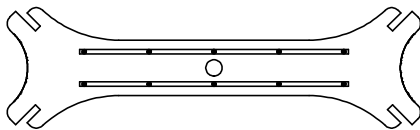

(D)

UPPER
DOG BONE
QTY. = 1

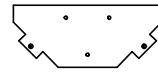

(E)

LEG BRACE
QTY. = 2



(F)

CORNER BLOCK
QTY. = 4

**PARTS REQUIRED
FOR ASSEMBLY**

1/5

KCF7455 MASON LARGE DINING TABLE

TOP
ASSEMBLY
QTY. = 1

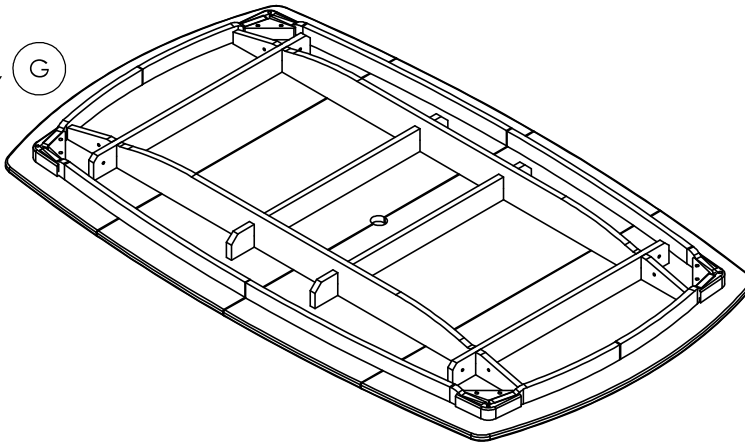

 (H) #8 X 2" SCREW
QTY. = ??

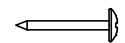
 (J) #10 X 1-1/2" SCREW
QTY. = 6

 (K) 1/4" FLAT WASHER
QTY. = 8

 (L) 1/4" X 1-1/2"
LAG SCREW
QTY. = 8

TOOLS REQUIRED (NOT INCLUDED)
#2 SQUARE DRIVE BIT
CORDLESS DRILL
RUBBER Mallet
7/16" WRENCH OR SOCKET

**PARTS & TOOLS
NEEDED
FOR ASSEMBLY**

2/5

KCF7455 MASON LARGE DINING TABLE

STEP 1: BEGIN BY IDENTIFYING THE LEFT AND RIGHT LEGS (A & B) BY THE SIDE THAT HAS THE COUNTERSINK ON THE PREDRILLED HOLES. THE COUNTERSUNK SIDES MUST FACE THE LONG SIDE OF THE TABLE.

ENGAGE THE SLOTS OF EACH LEG WITH THE SLOTS IN THE DOG BONE PIECES (C & D). INSURE THAT THE LOWER DOG BONE (C) IS THE ONE WITH THE METAL TUBES ON THE UNDERSIDE OF IT. ALSO, THE UPPER DOG BONE (D) MUST HAVE THE COUNTERSINKS FACING DOWN. TAP LIGHTLY WITH A RUBBER Mallet TO ENGAGE FULLY IF NEEDED.

ATTACH EACH OF THE 4 LEGS WITH (2) SCREWS (H) EACH.

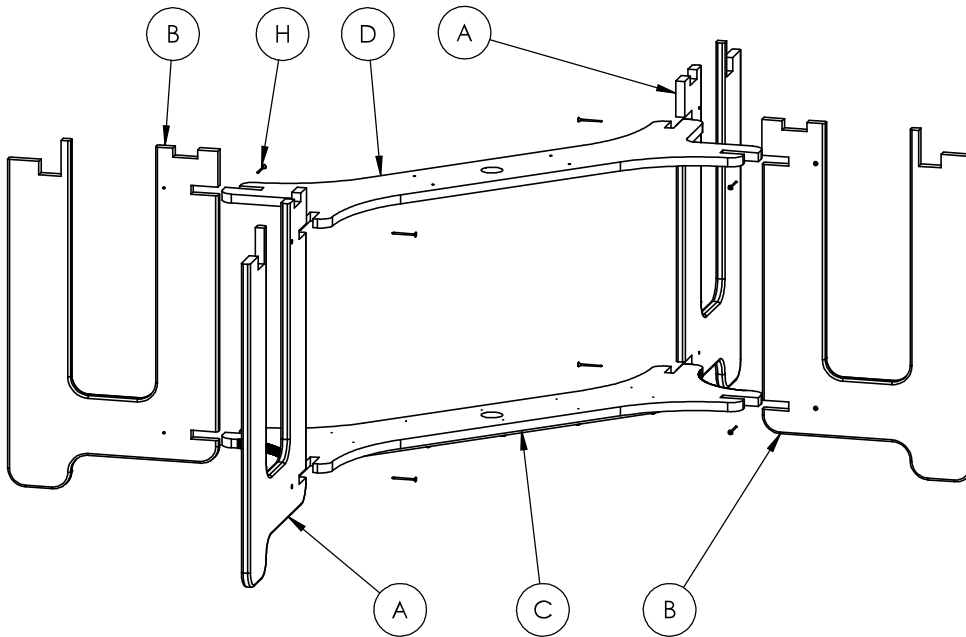

**ASSEMBLE LEGS
TO DOG BONES**

3/5

KCF7455 MASON LARGE DINING TABLE

STEP 2: NEXT, INSTALL THE LEG BRACES (E) AND CORNER BLOCKS (F) USING (2) #8 x 2" SCREWS (H) FOR EACH. BOTH THE LEG BRACES AND CORNER BLOCKS MUST BE INSTALLED WITH THE COUNTERSINKS FACING UP.

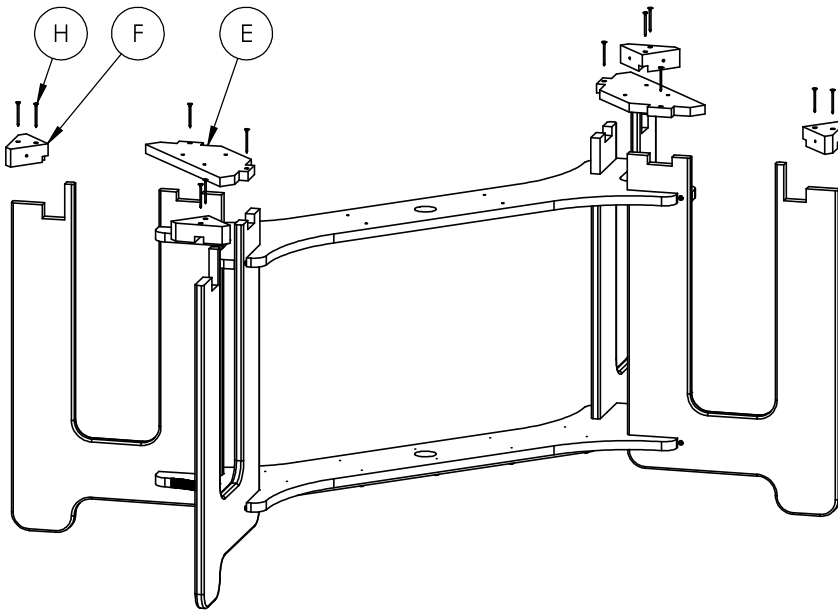

**INSTALL TOP
ATTACHMENT
POINTS**

4/5

KCF7455 MASON LARGE DINING TABLE

STEP 3: USING A HELPER, LIFT TOP ASSEMBLY ONTO LEG ASSEMBLY. MAKE SURE THE 4 CORNERS OF THE FRAMEWORK SETTLE INTO THE LARGE NOTCHES AT THE TOPS OF THE LEGS. ONCE IN PLACE, IT GETS FASTENED THREE DIFFERENT WAYS.

- 1) FASTEN (4) 2" SCREWS (H) UPWARD THROUGH THE UPPER DOG BONE (D).
- 2) FASTEN (6) #10 x 1-1/4" PANHEAD SCREWS (J) UPWARD THROUGH THE LEG BRACES (E).
- 3) AT THE CORNERS, ATTACH A 1/4" LAG SCREW (L) AND FLAT WASHER (K) THROUGH EACH PREDRILLED HOLE IN THE TOP FRAMEWORK, INTO THE CORNER BLOCKS (F).

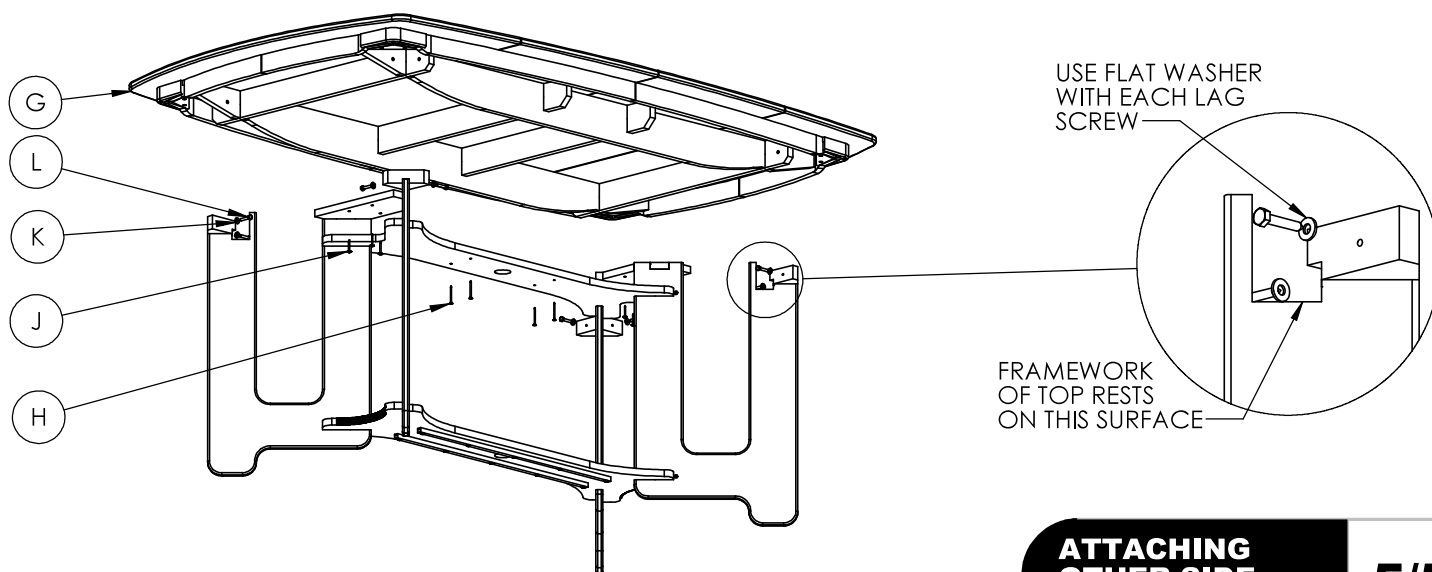

**ATTACHING
OTHER SIDE
FRAME**

5/5