

# **KBC7010 MASON BACKLESS BENCH**

KBC7010  
REV. 1  
12/2/25

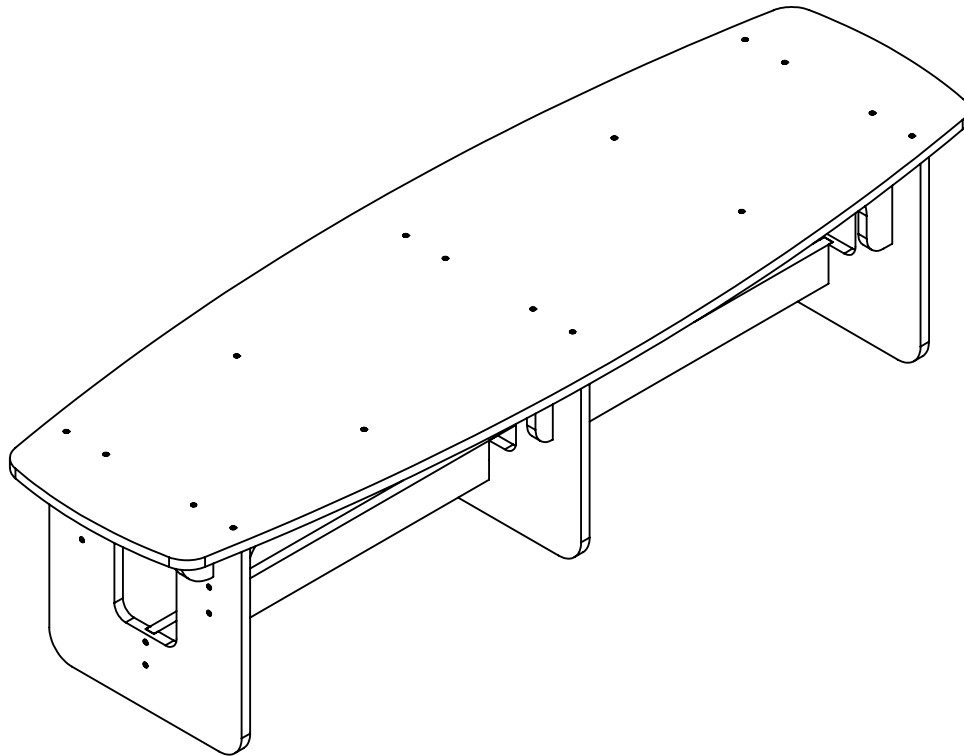

**ASSEMBLY  
INSTRUCTIONS**

# KBC7010 MASON BACKLESS BENCH

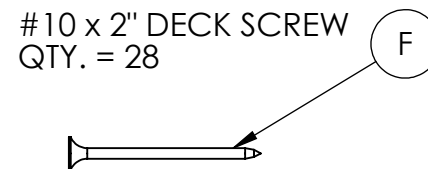
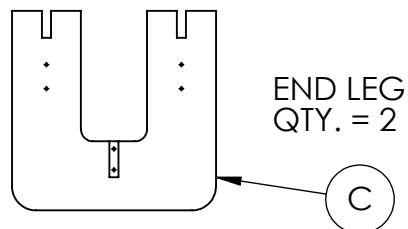
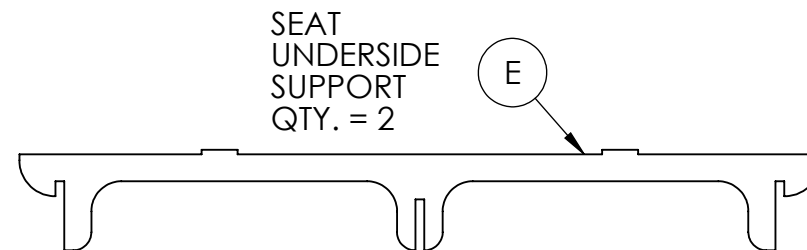
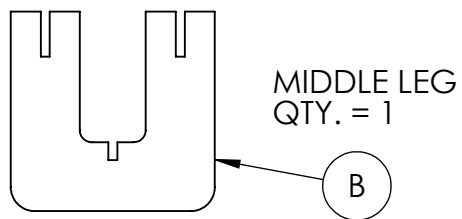
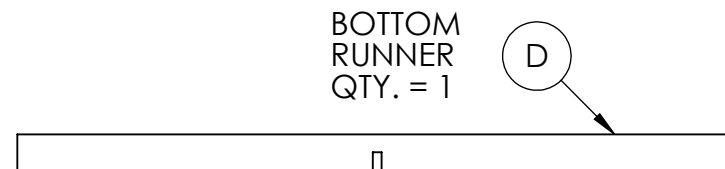
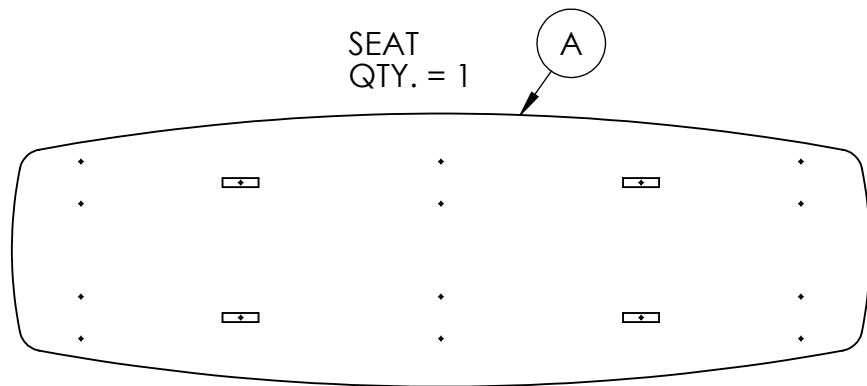

**COMPONENTS  
NEEDED**

**1/4**

# KBC7010 MASON BACKLESS BENCH

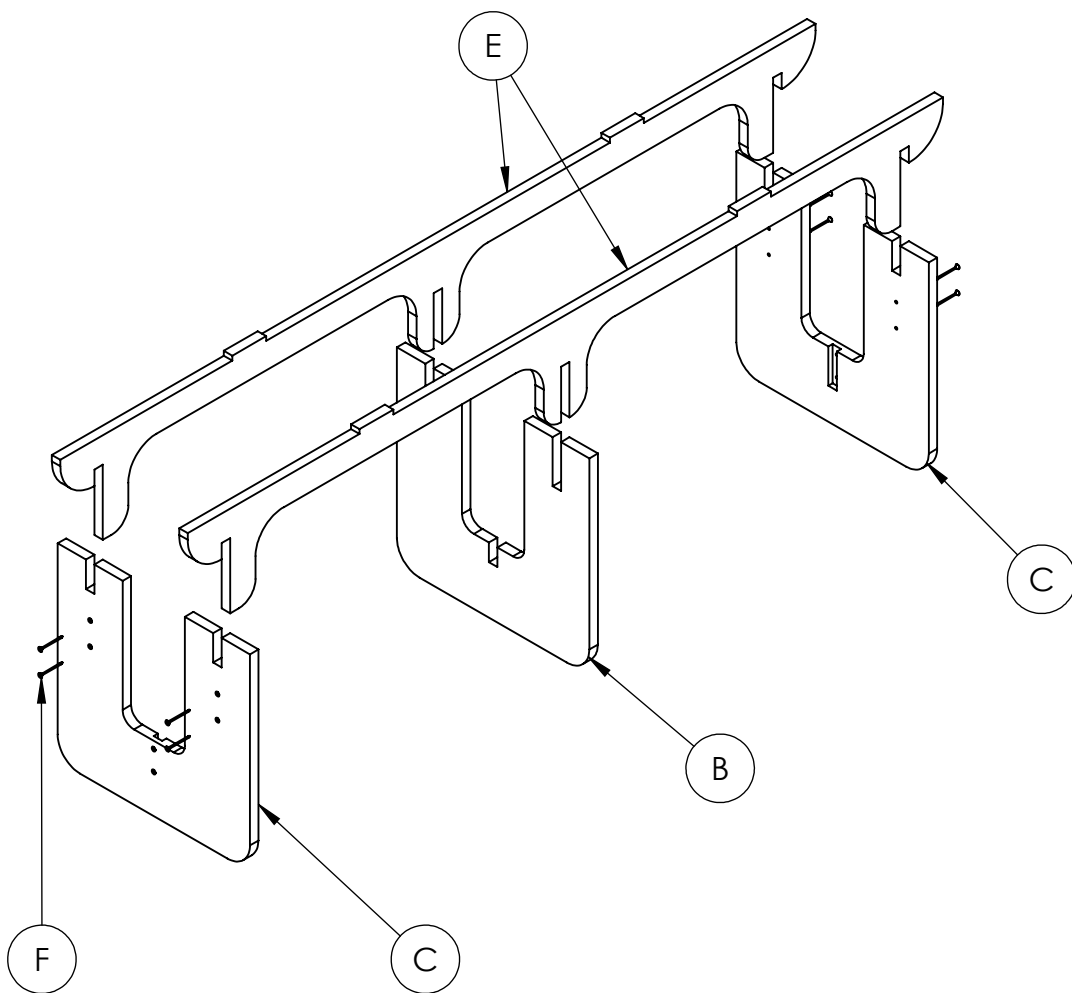

STEP 1: STAND THE CENTER LEG (B) UPRIGHT AND SLIP ONE SEAT UNDERSIDE SUPPORT (E) INTO ONE OF THE SLOTS. DO THE SAME THING WITH THE OTHER UNDERSIDE SUPPORT, SLIPPING IT INTO THE SLOT IN THE CENTER LEG. USE A RUBBER Mallet TO FULLY SEAT THE PARTS INTO ONE ANOTHER. NEXT, SLIP ONE END LEG (C) INTO THE END OF THE UNDERSIDE SUPPORTS. MAKE SURE THAT CUTOUT FACES INWARD (SEE DETAIL BELOW). DO THE SAME WITH THE OTHER END LEG AT THE OTHER END. INSTALL (8) #10x2" DECK SCREWS (F) THROUGH THE END LEGS INTO UNDERSIDE SUPPORT PIECES AS SHOWN.

**CONNECT  
LEGS**

**2/4**

# KBC7010 MASON BACKLESS BENCH

STEP 2: PLACE BOTTOM RUNNER (D) BETWEEN THE LEGS AS SHOWN. THE CENTER NOTCH WILL ENGAGE INTO THE CENTER NOTCH IN MIDDLE LEG. THE ENDS WILL SLIP INTO CUTOUTS IN THE END LEGS. USE RUBBER Mallet TO FULLY SEAT THE PIECES TOGETHER. NEXT, USE (4) #10x2" SCREWS (F) TO SECURE THE ENDS.

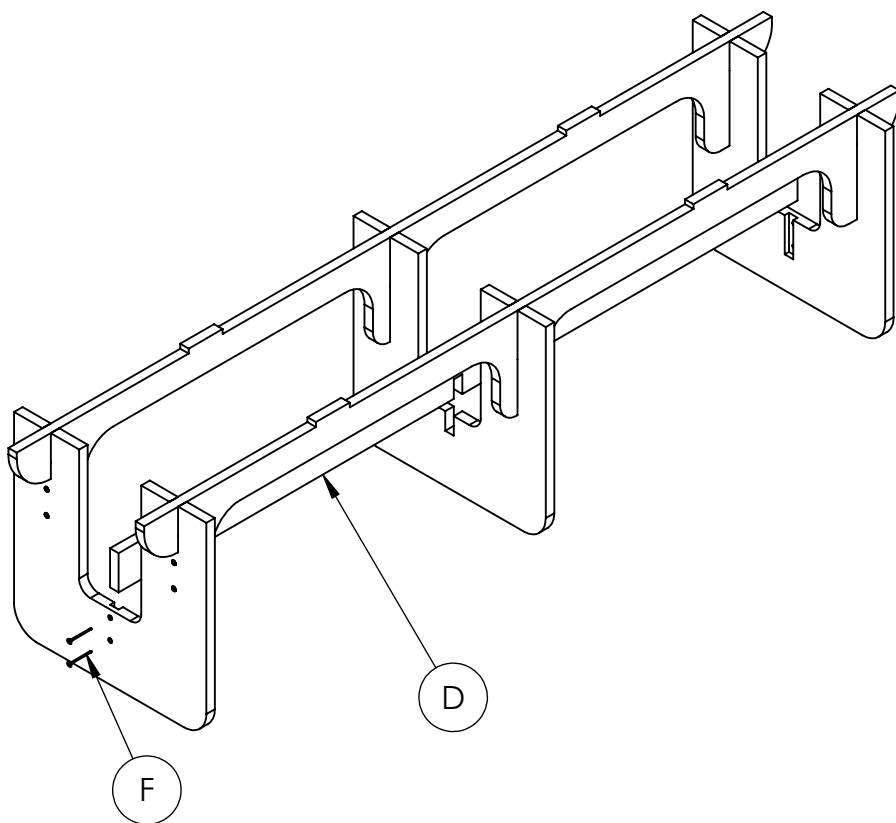

**INSTALL BOTTOM  
RUNNER**

**3/4**

# KBC7010 MASON BACKLESS BENCH

STEP 3: PLACE BENCH SEAT (A) ONTO LEGS AS SHOWN, WITH CUTOUTS FACING DOWNWARD. SEAT SHOULD BE FULLY SEATED ONTO THE UPWARD FACING TABS. SECURE USING (16) #10x2" SCREWS (F).

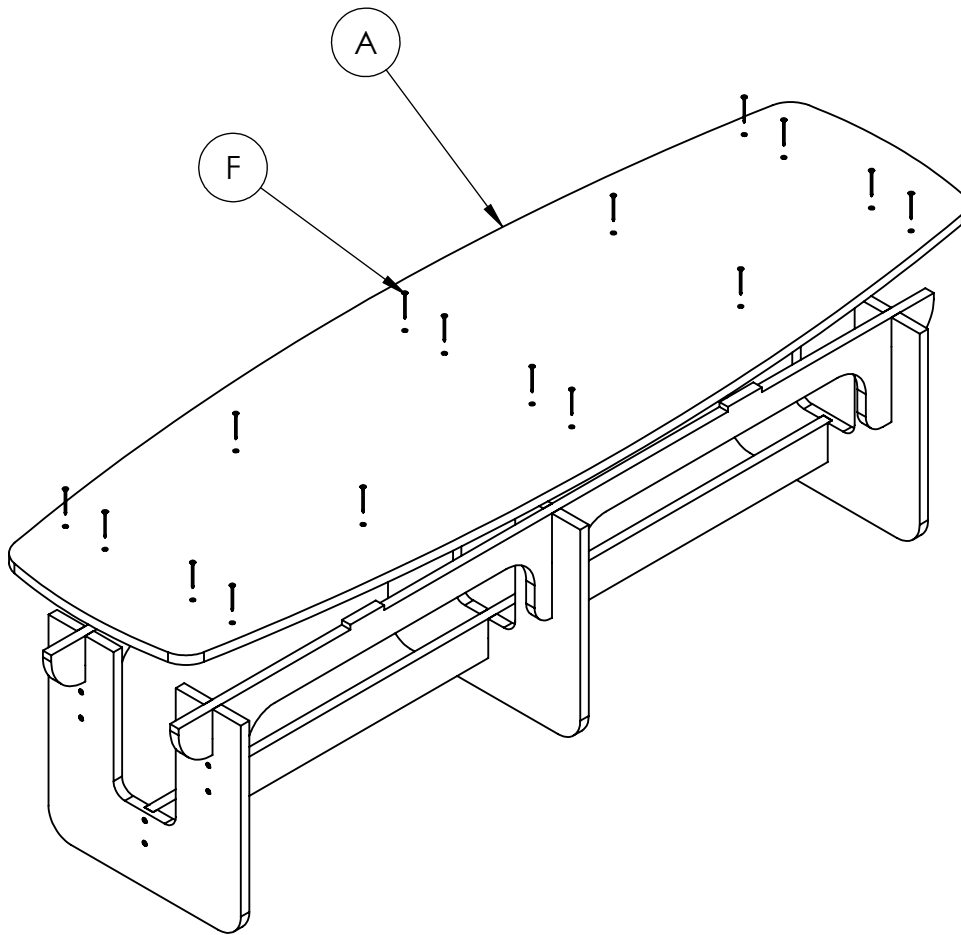

**INSTALL SEAT**

**4/4**

# KBC7010 MASON BACKLESS BENCH

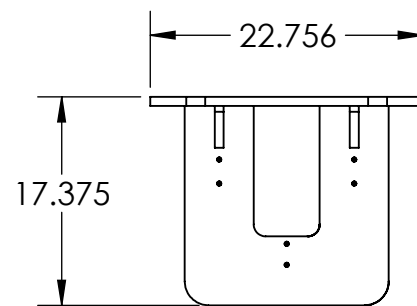
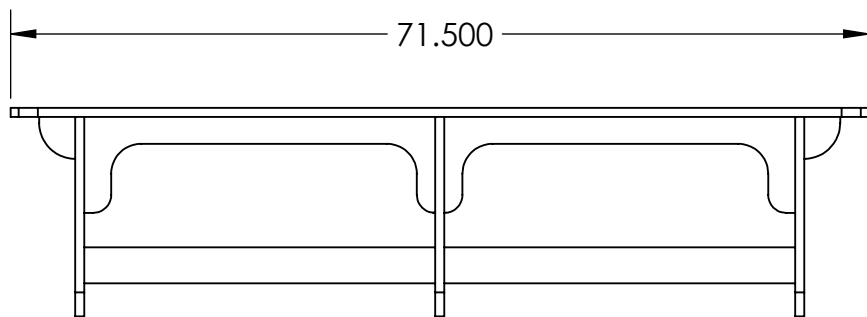
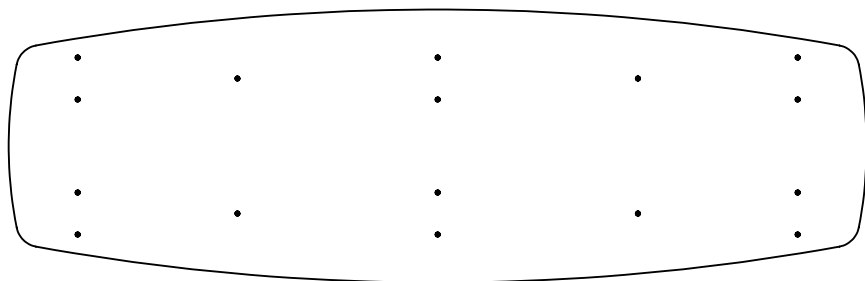

NOTE: ALL MATERIAL IS RECYCLED PLASTIC LUMBER UNLESS NOTED