

**GENERAL SHELTER SPECIFICATIONS:** QTY-\_\_ SHELTER(S)

A. GENERAL: Unassembled modular shelter is fabricated from low maintenance, lightweight corrosive resistant aluminum (factory fabricated). Site assembly required.

1 DIMENSIONS: 5'-0" wide x 10'-0" long, 97 5/8" nominal exterior height and 81 1/4" clearance height.

2 FRAME: Provide structural framing of 6063-T6 aluminum alloy extrusions. Members shall have a Quaker Bronze or Clear Anodized finish. Framing assembled using internally located mechanical fasteners. Exposed fasteners on framing system are not acceptable. Standard 7 3/4" ventilation space at bottom of unit. Two front openings.

3 ROOF: Constructed using a high impact White acrylic dome. Roof drains into full perimeter gutter system with drain holes.

4 WINDOWS: Fixed windows are single pane 1/4" clear tempered safety glass, glazed within wall system extrusions and not fastened to exterior wall. Glass sealed with concealed gasket system.

5 ANCHORING: Shelter installation requires concrete pad to be 12" minimum larger than shelter in both length and width dimensions. Pad must be level within 1/2" over length and width of structure. Shelter to be anchored to pad using height adjustable aluminum boot and anchored down using 1/4" X 1 7/8" Hilti Kwik Hus-EZ screw anchors.

6 BENCH: (Qty-1) Anodized aluminum bench system includes aluminum plank bench and aluminum plank backrest, end caps, brackets and hardware. Bench shall be shipped loose, and installed by others in the field. Bench size allows for shelter to be ADA-Compliant.

INSTALLATION: Unit is knocked down and crated, off loaded and installed by others.

**DESIGN LOADS**  
**WIND LOAD: 90 mph**  
**SNOW LOAD: 20 psf**

CERTIFICATION

Notice - The Company claims proprietary rights in the information disclosed on this drawing. It is issued in confidence for engineering information only and may not be used, in whole or in part, to manufacture anything whether or not shown hereon, reproduced or disclosed to anyone without direct written permission

TITLE: 5'-0" X 10'-0"  
ALUMINUM SHELTER

JOB NO:

QUOTE NO:

LOCATION:

MOD NO:

COLOR: SEE SPECIFICATIONS

DATE:

DRAWN BY: JRG

SCALE: N.T.S.

SHEET: 1 OF 2

**ELEVATION A**

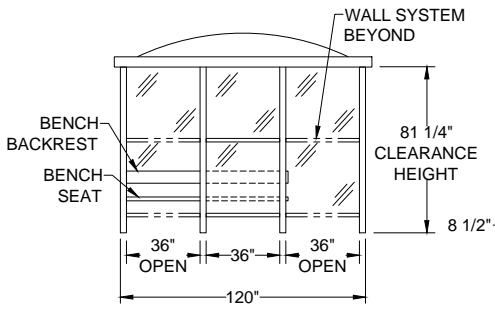

**ELEVATION B**

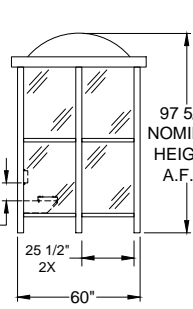

**ELEVATION C**

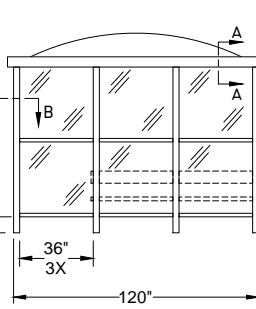

**ELEVATION D**

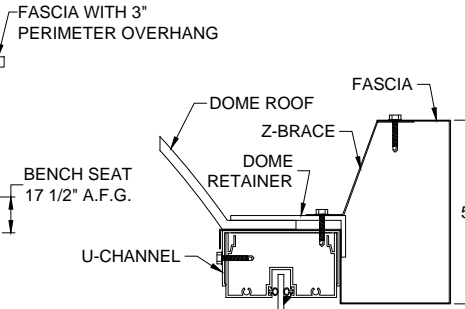
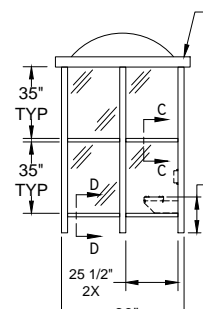

**VIEW A-A**

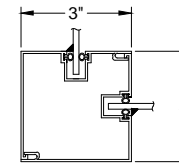

**VIEW B-B**

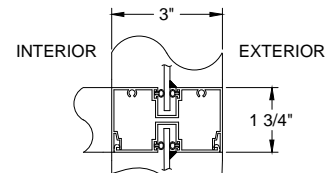

**VIEW C-C**

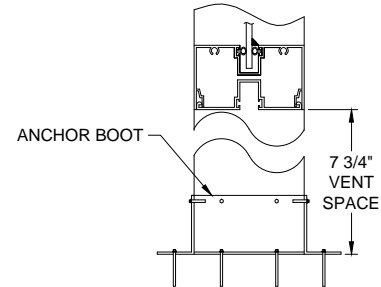

**VIEW D-D**

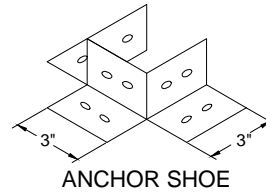

**ANCHOR SHOE**

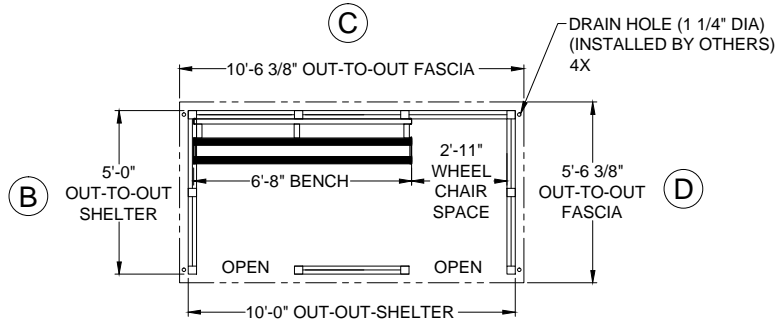

**PLAN VIEW**

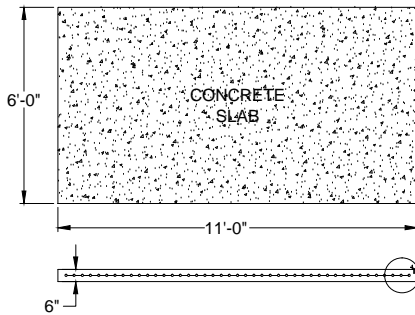

NOTE: CONCRETE SLAB DESIGN BY OTHERS, DIMENSIONS SHOWN ARE RECOMMENDED MINIMUM SIZES ONLY.

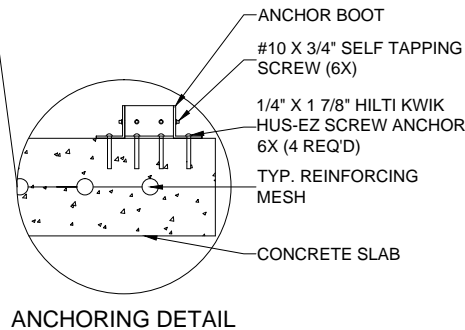

**ANCHORING DETAIL**

CERTIFICATION

Notice - The Company claims proprietary rights in the information disclosed on this drawing. It is issued in confidence for engineering information only and may not be used, in whole or in part, to manufacture anything whether or not shown hereon, reproduced or disclosed to anyone without direct written permission

TITLE:	5'-0" X 10'-0" ALUMINUM SHELTER
JOB NO:	
QUOTE NO:	
LOCATION:	
MOD NO:	
COLOR:	SEE SPECIFICATIONS
DATE:	
DRAWN BY:	JRG
SCALE:	N.T.S.
SHEET:	2 OF 2