

REF.#	PART DESCRIPTION	QTY.
1	Column - EMB Ø5" Swaged Umbrella	1
2	Crown - Ø5" With Six 2 7/8" Sockets	1
3	Rafter - Ø2 7/8" With Slotted Bracket	6
4	Glide - Ø2 7/8" Mechanized Insert	6
5	Strut - Ø1.9" Rigid	6
6	Fabric - Ø16' With Cable Insert	1
7	Frame Hardware Kit	1

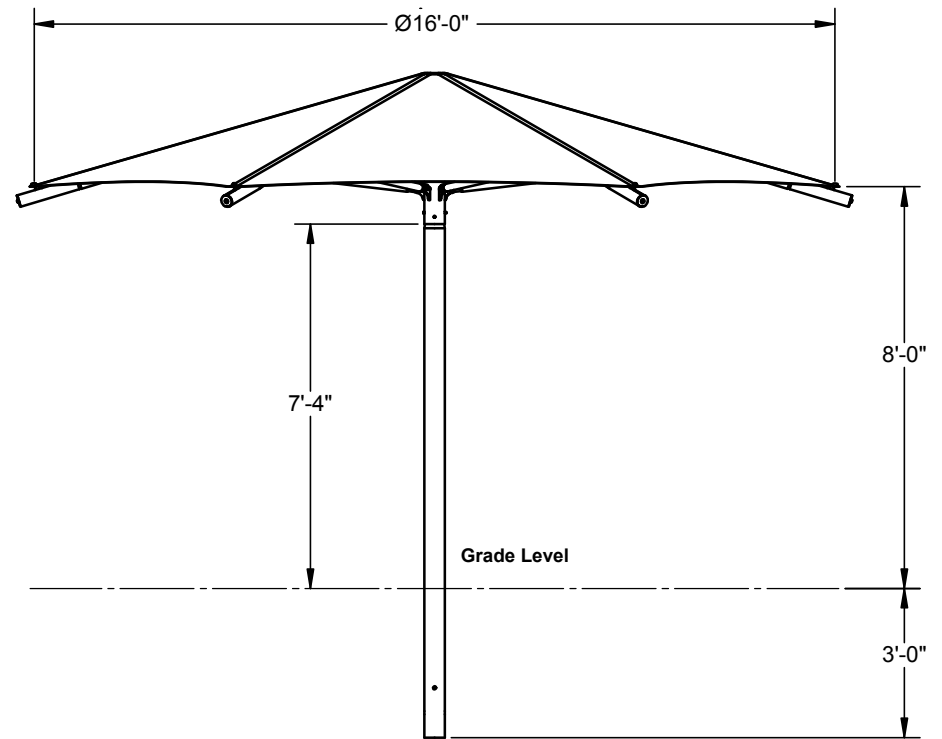

Description: Embedded Ø16' x 8' Hexagonal Umbrella		
Scale: Varies	Shade Style: Mech.	Sheet: 1 of 3
Date:	Units: Inches / Feet	Proposal No:

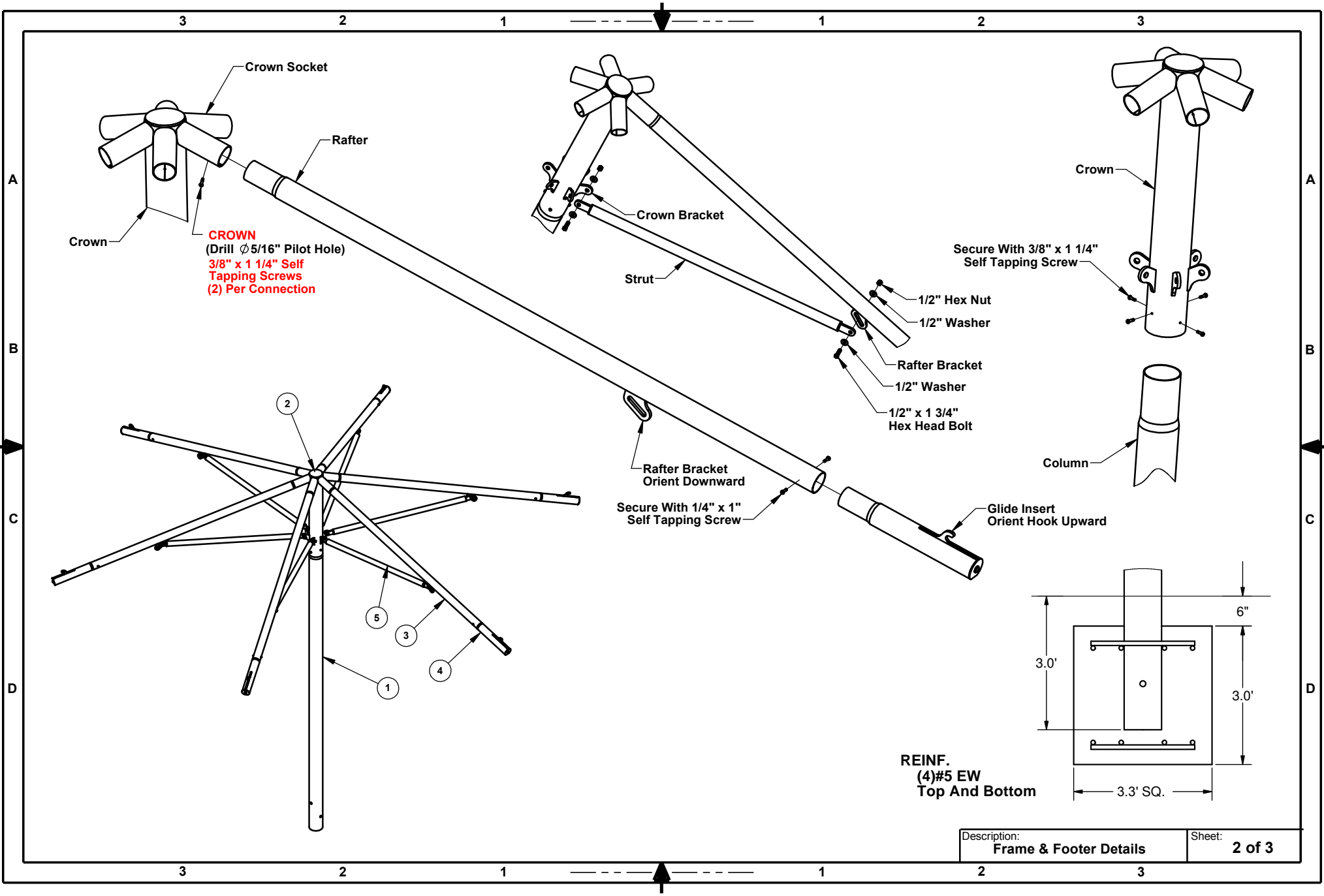

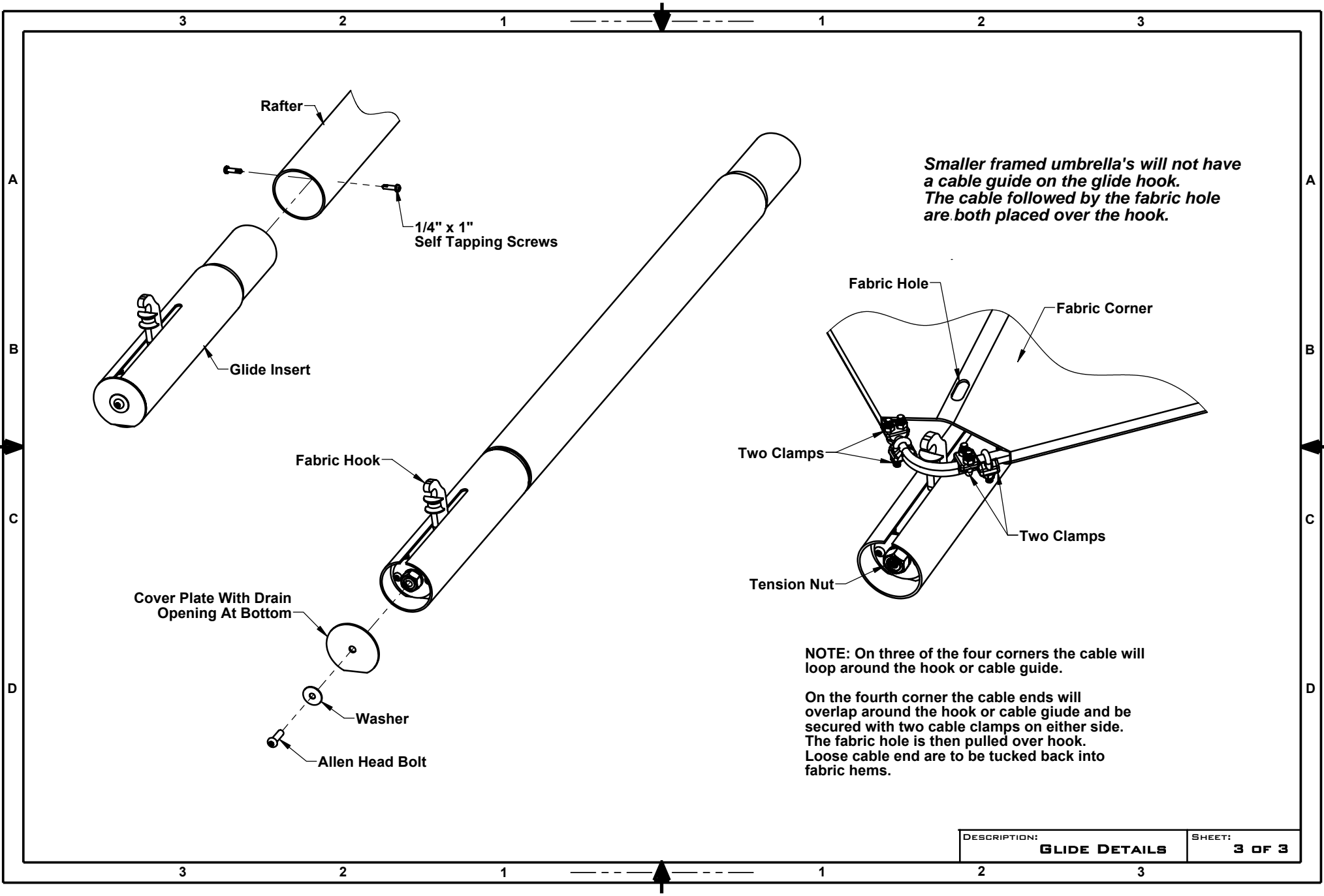

Smaller framed umbrella's will not have a cable guide on the glide hook. The cable followed by the fabric hole are both placed over the hook.

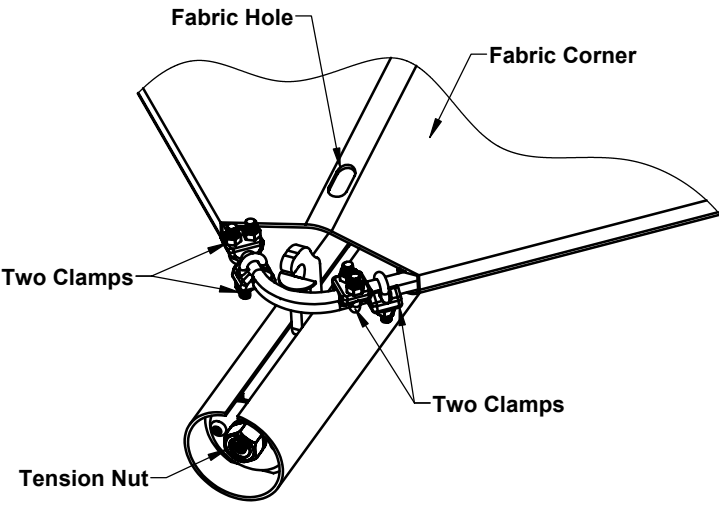

NOTE: On three of the four corners the cable will loop around the hook or cable guide.

On the fourth corner the cable ends will overlap around the hook or cable guide and be secured with two cable clamps on either side. The fabric hole is then pulled over hook. Loose cable end are to be tucked back into fabric hems.

SHADE STRUCTURE MATERIAL SPECIFICATIONS

Rev. 10/8/2012

1.01 FABRIC SPECIFICATIONS

- A. UV shade fabric is made of UV stabilized cloth manufactured by ALNET, or approved equal.
- B. The high density polyethylene material shall be manufactured with tensioned fabric structures in mind.
- C. The fabric knit is to be made using monofilament and tape filler which has a weight of 9.38 to 10.32 oz. sq. yd. Material to be Rachel-knitted to ensure material will not unravel if cut.
- D. Burst strength of 828 lbf (ASTM 3786).
- E. Cloth meets fire resistance tests as follows:
 - Alnet Extra Block: California State Fire Marshall Reg. #F-93501
 - Others: NFPA 701-99 (Test Method 2)
 - ASTM E-84
- F. Fabric Properties:

STRETCH	STENTORED
Tear Tests (lbs/ft)	WARP 44.8 WEFT 44
Burst Tests (lbs ft)	828
Fabric Weight (oz/sqFT) avg	1.02 to 1.07
Fabric Width	9'-10"
Roll Length	150'
Roll Size	63" x 16.5"
Weight	120 lbs.
Life Expectancy	10 years
Fading Note	Minimum fading after 6 years. 3 years for Red and Yellow.
Temperature	- 77 degrees
Maximum Temperature	+167 degrees

1.02 THREAD

- A. Shall be 100% expanded PTFE fiber which carries a 10 year warranty that is high strength and low shrinkage.
- B. Shall have a wide temperature and humidity range.
- C. Abrasion resistant and UV radiation immunity.
- D. Shall be unaffected by non-hydrocarbon based cleaning agents, acid rain, mildew, rot, chlorine, saltwater, and pollution.
- E. Lockstitch thread – 1200 Denier or equal.
- F. Chain stitch thread – 2400 Denier or equal.

1.03 STEEL TUBING

- A. All fabricated steel must be in accordance with approved shop drawings and calculations.
- B. All steel is cleaned, degreased or etched to ensure proper adhesion of powder-coat in accordance with manufacturer's specifications.
- C. All Steel used on this project needs to be new and accompanied by the mill certificates if requested. Structural steel tubing up to 5"-7" Gage shall be galvanized per Allied Steel FLO-COAT specifications. Schedule 40 black pipe fabrications shall be sandblasted and primed as described below.
- D. All non-hollow structural shapes comply with ASTM A-36, unless otherwise noted.
- E. All hollow structural steel shapes shall be cold formed HSS ASTM A-53 grade C, unless otherwise noted.
- F. Plate products shall comply with ASTM A-36.

1.04 POWDER COATING & PRIMING

- A. All non-galvanized steel shall be sandblasted and primed prior to powder coating using brown fused aluminum oxide grit and the following primer.
- B. All non-galvanized steel must be coated with rust inhibiting primer prior to applying the powder coat. Primer shall be Marine Grade Cardinal Industrial Finishes Corp. E396 – GR1372 epoxy powder coating semi-gloss smooth zinc rich primer.

- C. Welds shall be primed with rust inhibiting primer prior to applying the powder coat. Primer shall be Marine Grade Cardinal Industrial Finishes Corp E396-GR1372 epoxy powder coating semi-gloss smooth zinc rich primer.
- D. All steel parts shall be coated for rust protection and finished with a minimum 3.5 mil thick UV-inhibited weather resistant powder coating.
- E. Characteristics: Powder used in the powder-coat process shall have the following characteristics:

N.3.1	Specific gravity	1.68+/-0.05
N.3.2	Theoretical coverage	114+/- 4 ft 2/lb/mil
N.3.3	Mass loss during cure	< 1%
N.3.4	Maximum storage temperature	75 degrees F

- F. Powder-coating shall meet the following tests:

ASTM	Gloss at 60 degree	85-95
HOI TM 10.219	PCI Powder smoothness	7
ASTM D2454-91	Over-bake resistance time	200%
ASTM D3363-92A	Pencil hardness	H-2H
ASTM D2794-93	Dir/Rev Impact, Gardner	140/140 in/lbs
ASTM D3359-95B	Adhesion, cross hatch	5B Pass
ASTM D522-93A	Flexibility Mandrel	1/4" dia. No fracture
ASTM B117-95	Salt Spray	1,000 hours
UL DtOV2	Organic coating steel enclosures, elect eq.	Recognized

- G. Application Criteria:

N.5.1	Electrostatic spray cold	Substrate:0.032 in. CRS
N.5.2	Cure Schedule	10 minutes at 400 degrees F
N.5.3	Pretreatment	Bonderite 1000
N.5.4	Film Thickness	3.5 Mils

1.05 WELDING

- A. All shop welds shall be executed in accordance with the latest edition of the American Welding Society Specifications.
- B. Welding procedures shall comply in accordance with the AWS D1.1-AWS Structural Welding Code-Steel.

- C. All welds to be performed by a certified welder. All welds shall be continuous where length is not given, unless otherwise shown or noted on drawings.
- D. All welds shall develop the full strength of the weaker member. All welds shall be made using E70xx.035 wire.
- E. Shop connections shall be welded unless noted otherwise. Field connections shall be indicated on the drawings. Field –welded connections are not acceptable.
- F. All fillet welds shall be a minimum of 1/4” unless otherwise noted.
- G. All steel shall be welded shut at terminations to prevent internal leakage.
- H. Internal weld sleeving is not acceptable.
- I. On-site welding of any component is not acceptable.

1.06 SEWING

- A. On-site sewing of a fabric will not be accepted.
- B. All corners shall be reinforced with extra non-tear cloth and strap to distribute the load.
- C. The perimeters that contain the cables shall be double lock stitched.

1.07 INSTALLATION HARDWARE

- A. Bolt and fastening hardware shall be determined based on calculated engineering loads.
- B. All bolts shall comply with SAE-J429 (Grade 8) or ASTM A325 (Grade BD). All nuts shall comply with ASTM F-594, alloy Group 1 or 2.
- C. Upon request, Stainless Steel hardware shall comply with ASTM A-304.
- D. 1/4” galvanized wire rope shall be 7x19 strand with a breaking strength of 7,000 lbs. for shades generally under 575 sq. ft. unless requested larger by the customer. For shades over 575 sq. ft., cable shall be 5/16” with a breaking strength of 9,800 lbs. Upon request, 1/4” Stainless Steel wire rope shall be 7x19 strand with a breaking strength of 6,400 lbs. 5/16” Stainless Steel wire rope shall be 7/19 strand with a breaking strength of 9,000 lbs.
- E. All fittings required for proper securing of the cable are hot dipped galvanized.

1.08 CONCRETE

- A. Concrete work shall be executed in accordance with the latest edition of American Concrete Building Code ACI 318 unless specified by the governing municipality.
- B. Concrete specifications shall comply in accordance with, and detailed as per plans as follows:
 - 1. 28 Days Strength $F'_c = 2500$ psi
 - 2. Aggregate: HR
 - 3. Slump: 3-5
 - 4. Portland Cement shall conform to C-150
 - 5. Aggregate shall conform to ASTM C-33
- C. All reinforcement shall conform to ASTM A-615 grade 60.
- D. Reinforcing steel shall be detailed, fabricated and placed in accordance with the latest ACI Detailing Manual and manual of Standard Practice
- E. Whenever daily ambient temperatures are below 80 degrees Fahrenheit, the contractor may have mix accelerators and hot water added at the batch plant (See Table 1).
- F. The contractor shall not pour any concrete when daily ambient temperature is below 55 degrees Fahrenheit.

Temperature Range	% Accelerator	Type Accelerator
75-80 degrees	1%	High Early (non calcium)
70-75 degrees	2%	High Early (non calcium)
Below 70 degrees	3%	High Early (non calcium)

1.09 FOOTINGS

- A. All anchor bolts set in new concrete shall be ASTM A-307, or ASTM F-1554 if specified by engineer.
- B. All anchor bolts shall be zinc plated unless specified otherwise.
- C. Footing shall be placed in accordance with and conform to engineered specifications and drawings.