

INSTRUCTIONS

ADP1000 REV# 2
ADP1005

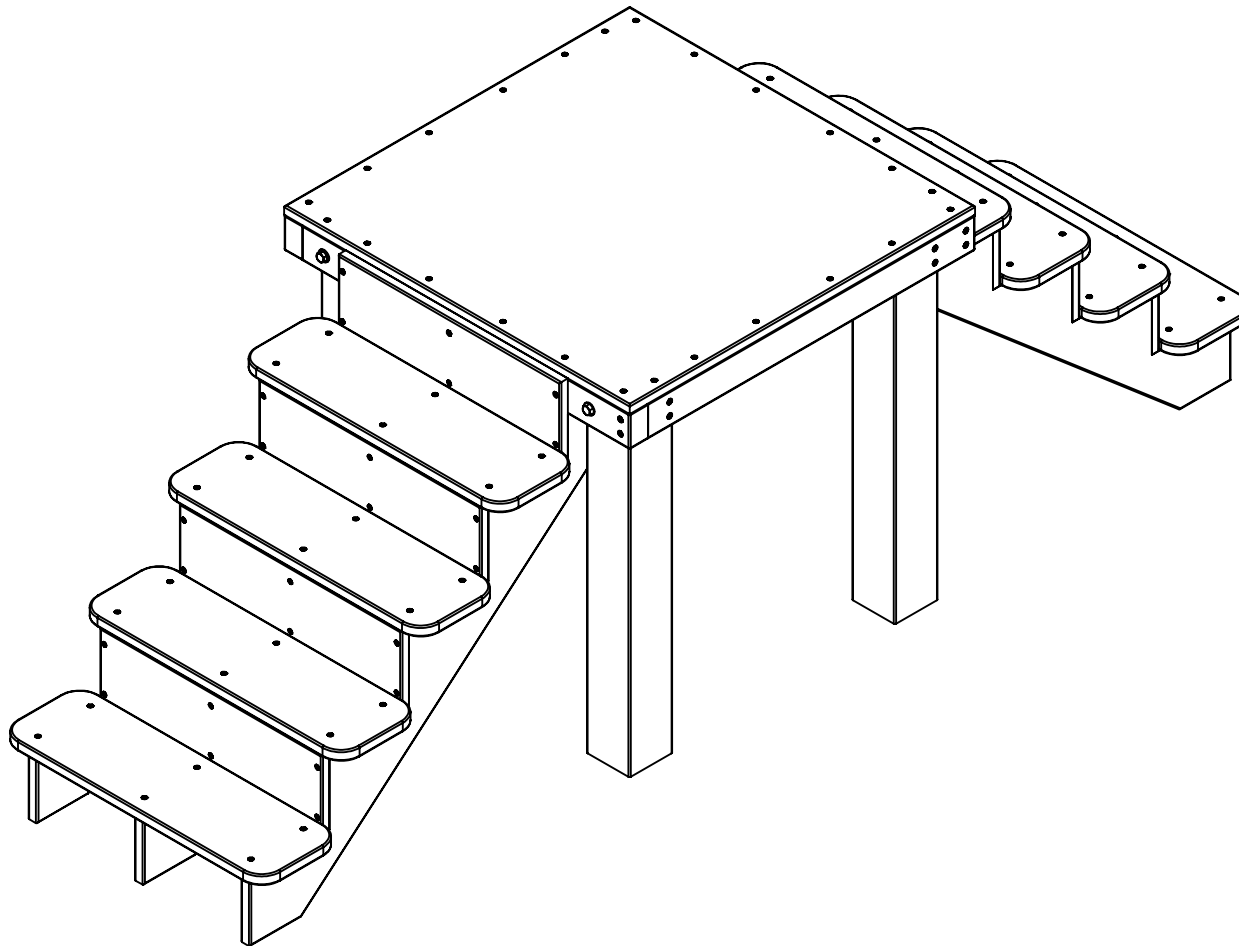

INSTRUCTIONS

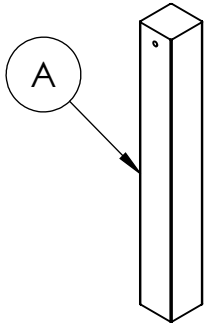

4
4x4 POSTS

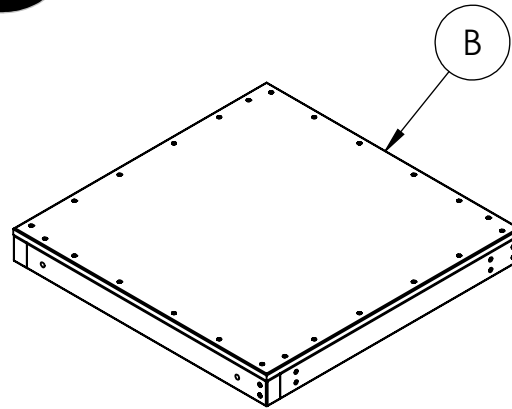

1
PLATFORM

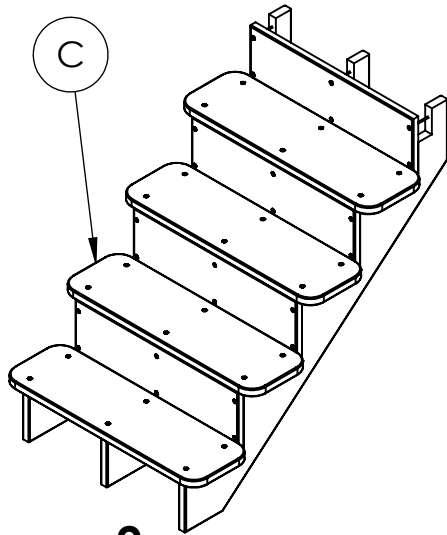

2
STAIR ASSEMBLY

REQUIRED TOOLS (NOT INCLUDED)

- POWER DRILL
- (2) 9/16 WRENCHES OR SOCKETS
- #2 SQUARE DRIVE

HARDWARE

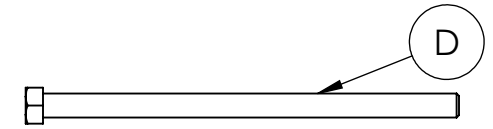

4
3/8" x 5.5" HEX BOLTS

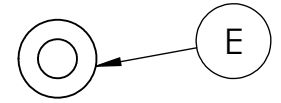

8
3/8" WASHERS

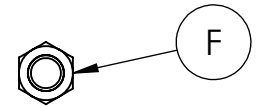

4
3/8" HEX NUTS

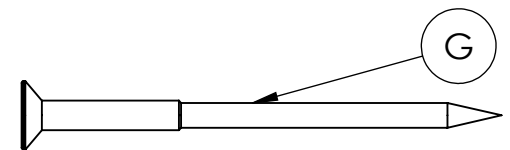

14
#10 x 2.5"
FLAT HEAD SCREW

**HARDWARE &
TOOLS REQUIRED
FOR ASSEMBLY**

2/5

INSTRUCTIONS

INGROUND MOUNT ONLY

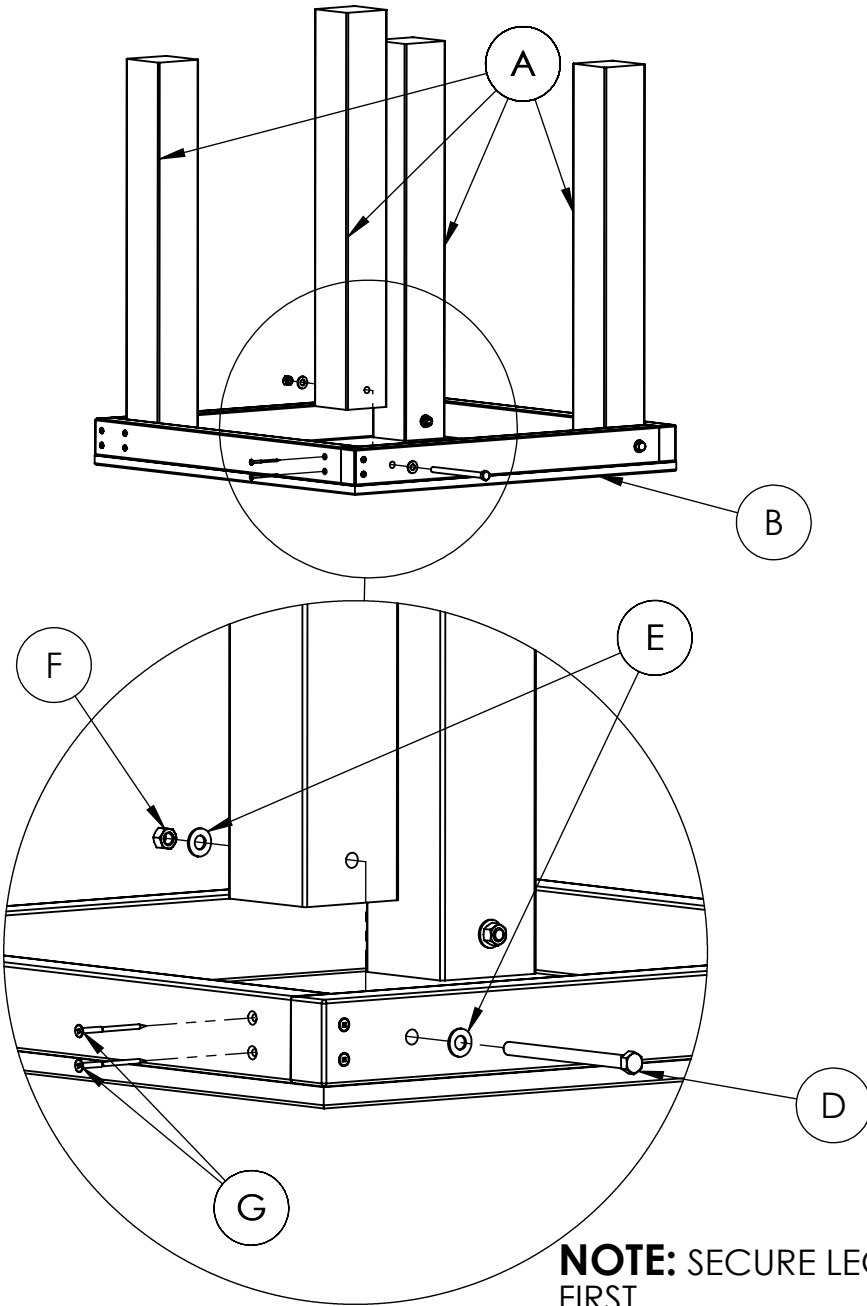

**MUST BE
THIS HEIGHT
ABOVE GROUND**

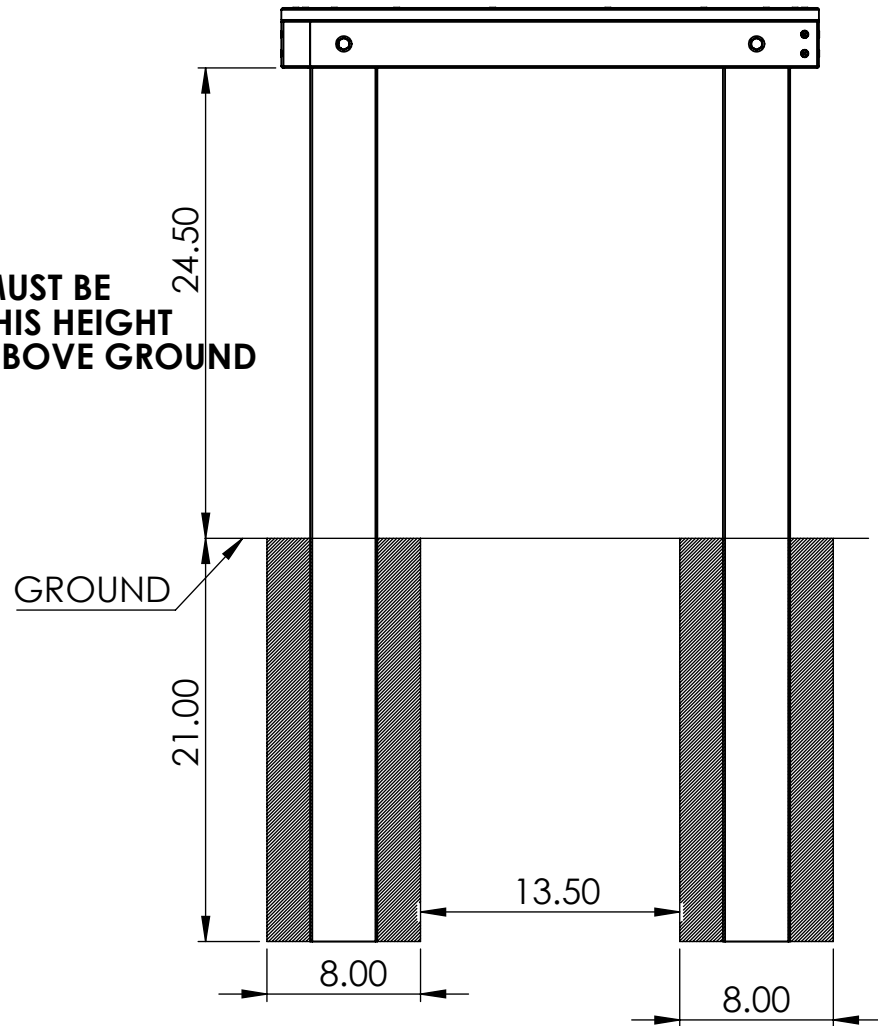

NOTE: SECURE LEGS WITH BOLTS FIRST

INSTRUCTIONS

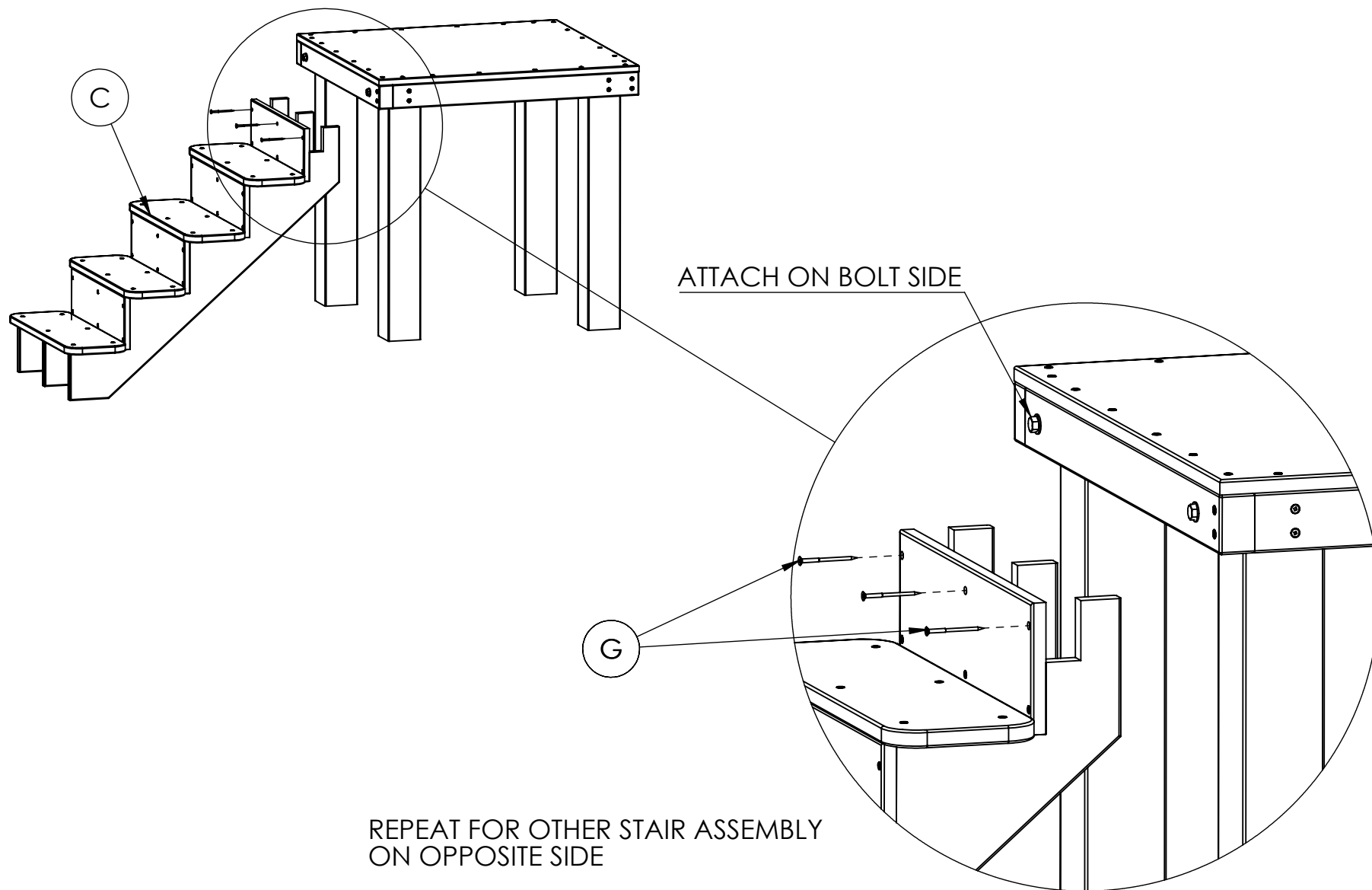

SPECIFICATIONS

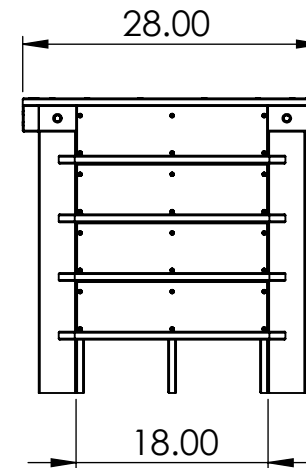
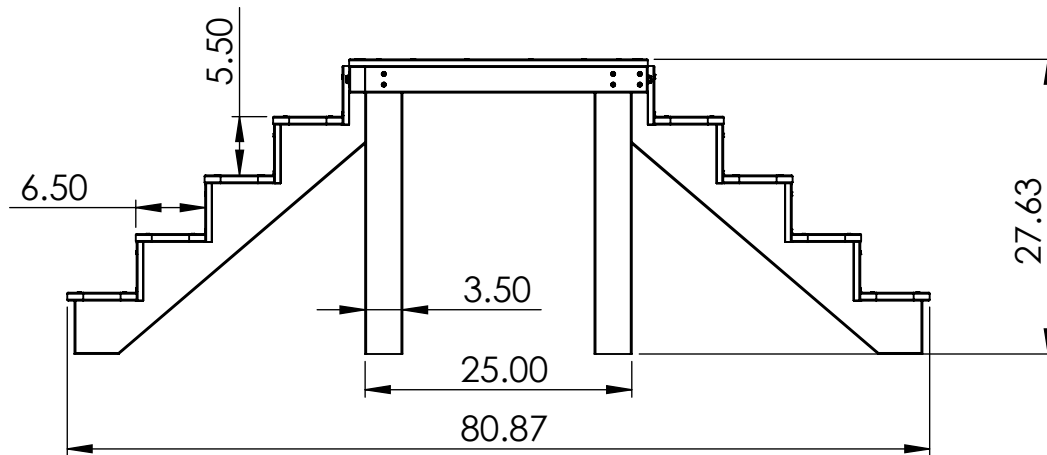
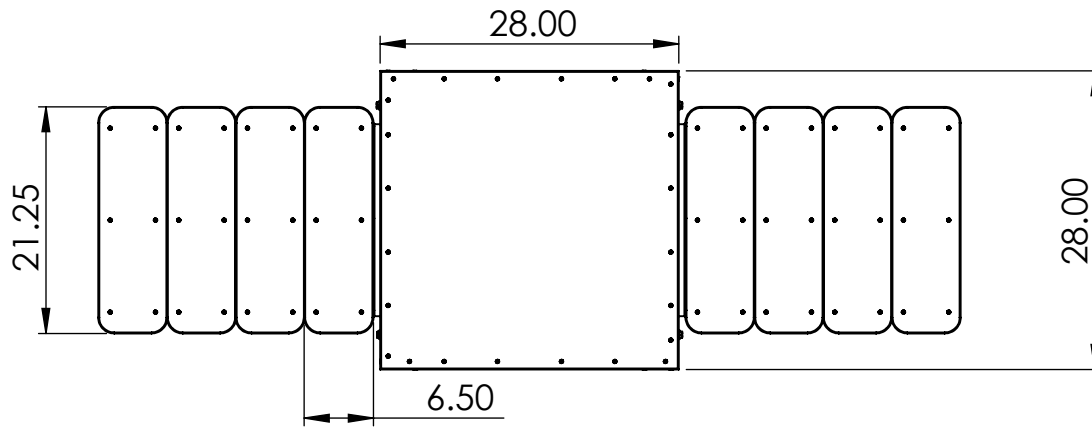
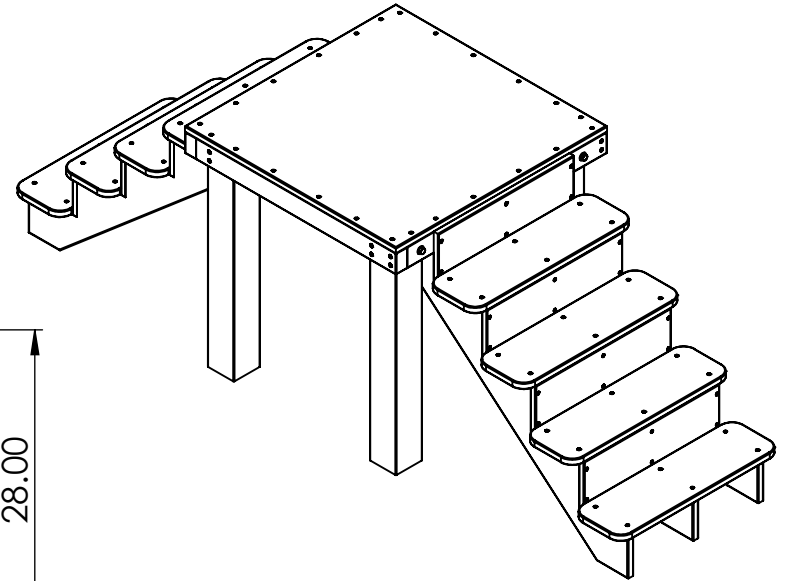

CONSTRUCTION MATERIALS:
Recycled Plastic
HARDWARE:
Stainless Steel

ALL DIMENSIONS SHOWN IN INCHES